



SECTION 47

Displays and Samples

IN THIS CATALOG SECTION

PAGE NUMBER	CONTENTS
47-02	Flat Chain and Turkey Feeding
47-03	Pan Feeding - Broiler
47-04	Pan Feeding - Pullet and Breeder & Chick Feeders & Poly Hopper
47-05	Post Display
47-06	Line Display
47-07	Watering
47-08	Nesting and Oasis Cool Cell System
47-09	Signs and Flexible Auger

VAL-CO DEALER SAMPLES AND DISPLAYS

Contact your VAL-CO Sales person to inquire about using AgVantage™ funds for displays

CHAIN FEEDING

CATALOG #	ITEM DESCRIPTION	SHIP WEIGHT		LIST PRICE
		LBS.	KG.	
7701971	DISPLAY, CLEAR CHAIN DISK CORNER (18" x 24")	20.0	9.1	
7703580	DISPLAY, TROUGH/CORNER/GRILL FLAT CHAIN	55.0	24.9	



7701971

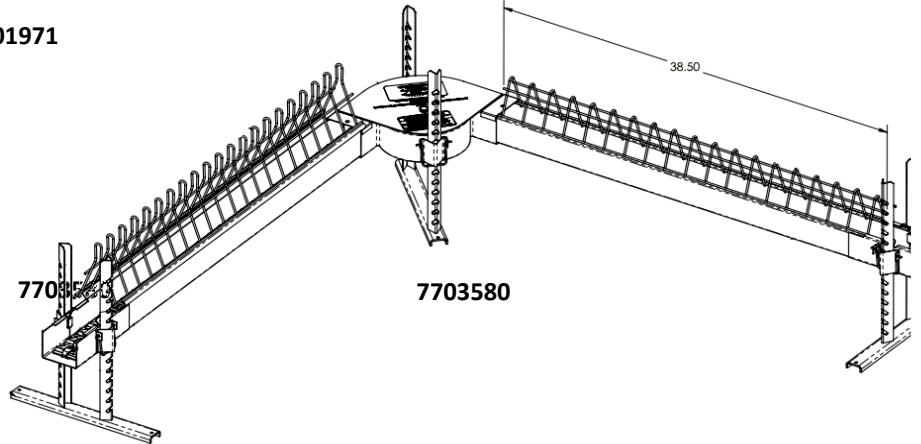

PAN FEEDING - TURKEY

CATALOG #	ITEM DESCRIPTION	SHIP WEIGHT		LIST PRICE
		LBS.	KG.	
460229	Adult Turkey Pan Feeder Sample - with Tube	6.7	3.0	
460207	PEAK Turkey Poult Pan Feeder Sample - with Tube	2.0	0.9	
FE1800RS-SAMP	14" FUZE Pro 5-Spoke Standard Pan 2-Piece Sample - with Tube	2.5	1.1	
451012	Feed Tube Sample - 1.75" x 12" LOCK-SEAM with Cutout	0.8	0.4	
450179	Feed Tube Sample - 1.75" x 12" SMOOTH with Cutout	0.7	0.3	
460063	Turkey Tube Sample - 2" x 12" SMOOTH with Cutout	0.0	0.0	

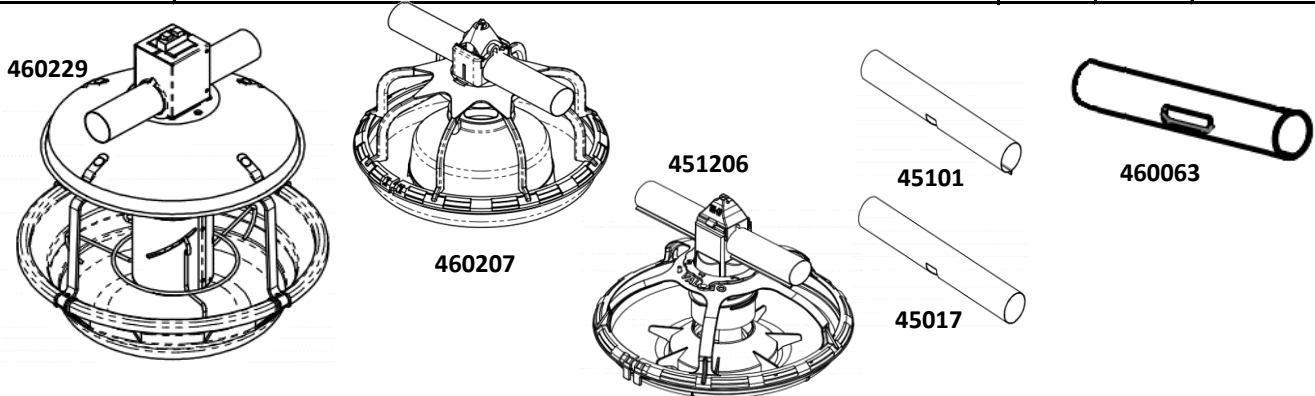

VAL-CO DEALER SAMPLES AND DISPLAYS

Contact your VAL-CO Sales person to inquire about using AgVantage™ funds for displays

PAN FEEDING - BROILER		SHIP WEIGHT		LIST PRICE
		LBS.	KG.	
CATALOG #	ITEM DESCRIPTION			
FE1500RS-SAMP-LS	FUZE Pro 13" Standard Pan Two-piece with tube	3.6	1.6	
FE1500RS-S-SAMP-LS	FUZE Pro 13" Standard Pan One-piece with tube	2.2	1.0	
FE1600RS-SAMP-LS	FUZE Pro 14" Standard Pan Two-piece with tube	3.6	1.6	
FE1600RS-S-SAMP-LS	FUZE Pro 14" Standard Pan One-piece with tube	2.6	1.2	
FE1800RS-SAMP-LS	FUZE Pro 14" Standard Pan Two-piece with tube - 5-spoke	3.6	1.6	
FE1800RS-S-SAMP-LS	FUZE Pro 14" Standard Pan One-piece with tube - 5-spoke	2.6	1.2	
FE1500RLS-SAMP-LS	FUZE Pro 13" Shallow Pan Two-piece with tube	3.5	1.6	
FE1500RLS-S-SAMP-LS	FUZE Pro 13" Shallow Pan One-piece with tube	2.2	1.0	
FE1600RLS-SAMP-LS	FUZE Pro 14" Shallow Pan Two-piece with tube	3.5	1.6	
FE1600RLS-S-SAMP-LS	FUZE Pro 14" Shallow Pan One-piece with tube	2.6	1.2	
FE1800RLS-SAMP-LS	FUZE Pro 14" Shallow Pan Two-piece with tube - 5-spoke	3.6	1.6	
FE1800RLS-S-SAMP-LS	FUZE Pro 14" Shallow Pan One-piece with tube - 5-spoke	2.6	1.2	
451012	Feed Tube Sample - 1.75" x 12" LOCK-SEAM with Cutout	0.8	0.4	
450179	Feed Tube Sample - 1.75" x 12" SMOOTH with Cutout	0.7	0.3	

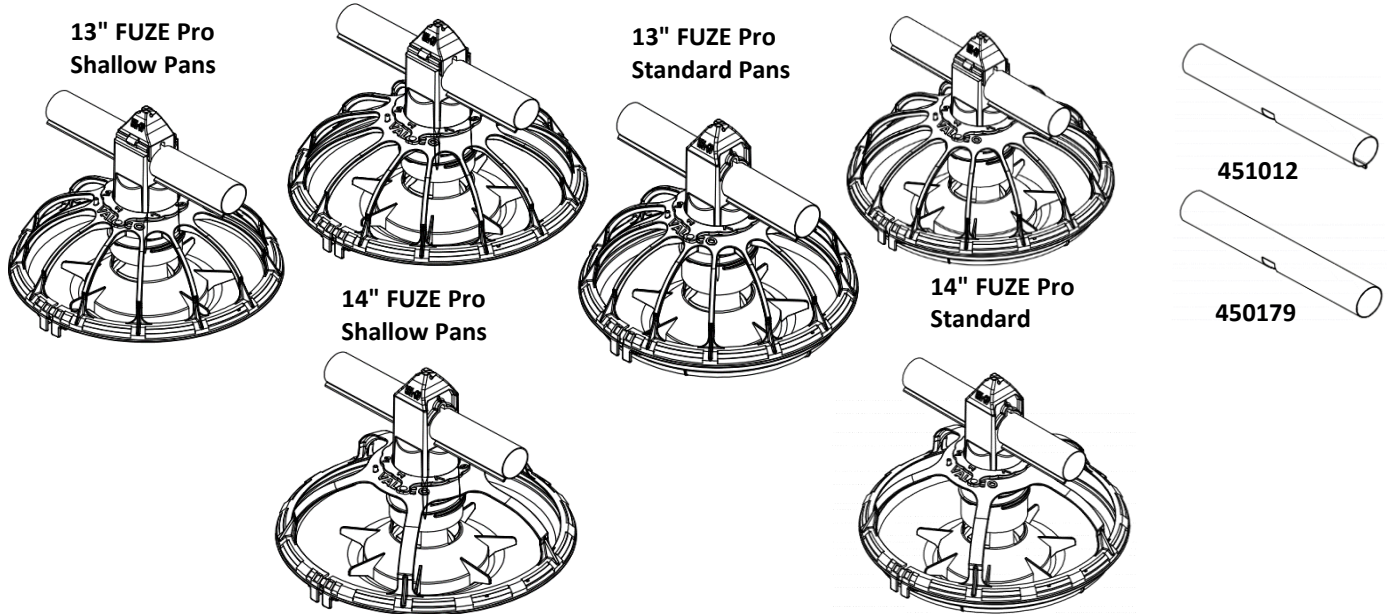

VAL-CO DEALER SAMPLES AND DISPLAYS

Contact your VAL-CO Sales person to inquire about using AgVantage™ funds for displays

PAN FEEDING - PULLET AND BREEDER

CATALOG #	ITEM DESCRIPTION	SHIP WEIGHT		LIST PRICE
		LBS.	KG.	
FE1800RS-1PSO	FUZE Pro 14" Standard Pan One-piece - 5-spoke with Shutoff	2.1	0.9	
FE1800RS-SO	FUZE Pro 14" Standard Pan Two-piece - 5-spoke with Shutoff	2.1	0.9	
FE1800RLS-1PSO	FUZE Pro 14" Shallow Pan One-piece - 5-spoke with Shutoff	2.1	0.9	
451206	PXR Hi-Cap (approx. 3#) Rooster Feed Pan Sample - Wire Grill	3.6	1.7	
451030	PXR Rooster Feed Pan Sample - Plastic Grill - with Shutoff	2.3	1.0	

FE1800RS-1PSO

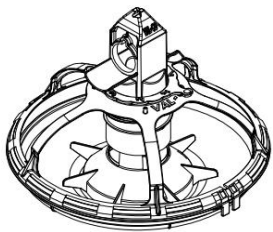

FE1800RS-SO

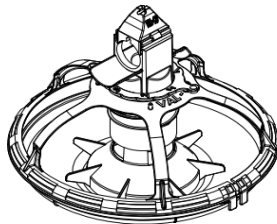

FE1800RLS-1PSO

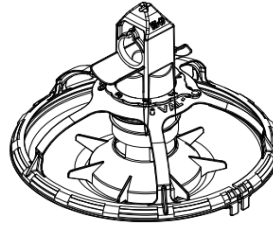

4512

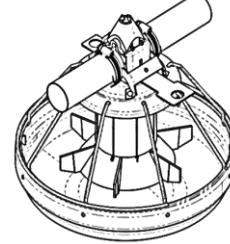

450130

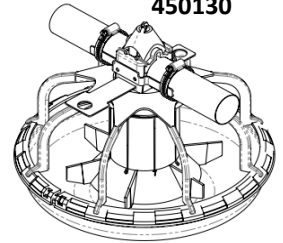

CHICK FEEDERS

820221	Clean Start Feeder	1.7	0.8	
820194	Ultra Start Feeder	1.4	0.6	
820192	Ultra Start Feeder Storage Kit	0.2	0.1	

820221

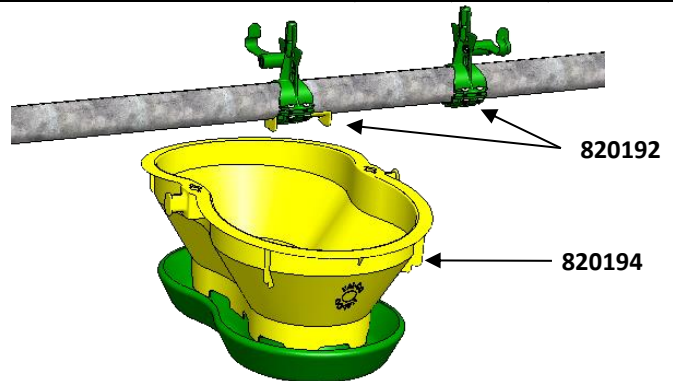

POLY HOPPER

7702317	Poly Hopper Display	76.0	34.5	
---------	---------------------	------	------	--

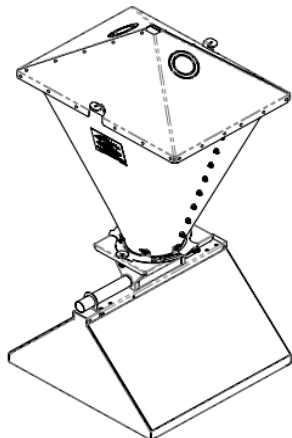

VAL-CO DEALER SAMPLES AND DISPLAYS

Contact your VAL-CO Sales person to inquire about using AgVantage™ funds for displays

Post Display		SHIP WEIGHT		LIST PRICE
CATALOG #	ITEM DESCRIPTION	LBS.	KG.	
7702060	Single Post Display (6 Pegs)	40.0	18.1	

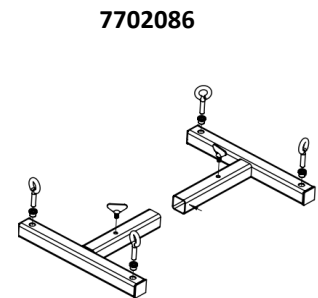
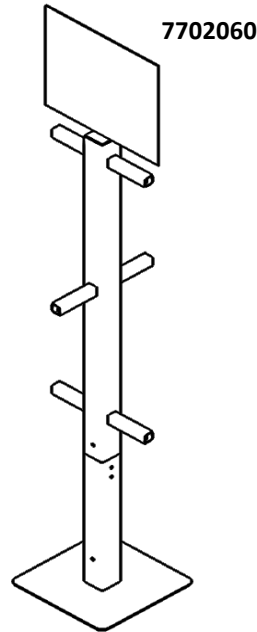
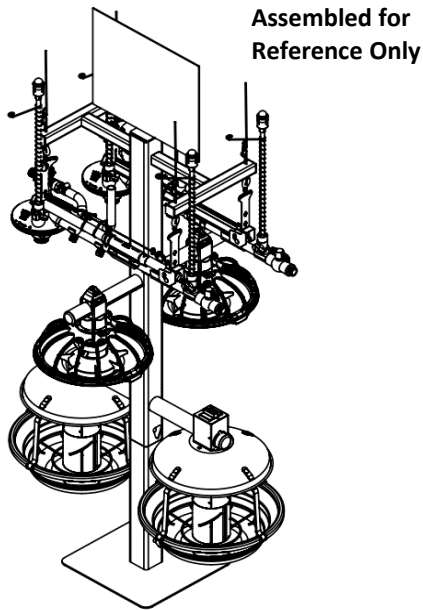

Choose Post Displays

CATALOG #	ITEM DESCRIPTION	SHIP WEIGHT		LIST PRICE
		LBS.	KG.	
7702086	Water Line Hanger for Post Display (order 2 Watering Line Samples)	6.0	2.7	
7702080	11 7/8" Long Turkey Tube Assembly (Order 1 Adult Turkey Pan)	1.2	0.5	
7702081	11 1/2" Smooth Tube Assembly (Order 1 broiler, rooster, poult, or layer Feed Pan)	0.8	0.3	
7702083	11 1/2" Ribbed Tube Assembly (Order 1 broiler, rooster, poult, or layer Feed Pan)	2.6	1.2	

VAL-CO DEALER SAMPLES AND DISPLAYS

Contact your VAL-CO Sales person to inquire about using AgVantage™ funds for displays

Line Display

CATALOG #	ITEM DESCRIPTION	SHIP WEIGHT		LIST PRICE
		LBS.	KG.	
7702070	4 Line Display	89.0	40.4	

Choose Line Displays

CATALOG #	ITEM DESCRIPTION	SHIP WEIGHT		LIST PRICE
		LBS.	KG.	
7702084	48" Adult Turkey Line Display (includes 2 Pans)	18.2	8.3	
7702085	48" Ribbed Tube Display (Order 2 broiler, rooster, poult, or layer Feed Pans)	3.6	1.6	
7702090	40" Turkey Bell Drinker Display	7.4	3.3	
7702091	40" Big Tom Water Line Display	3.0	1.4	

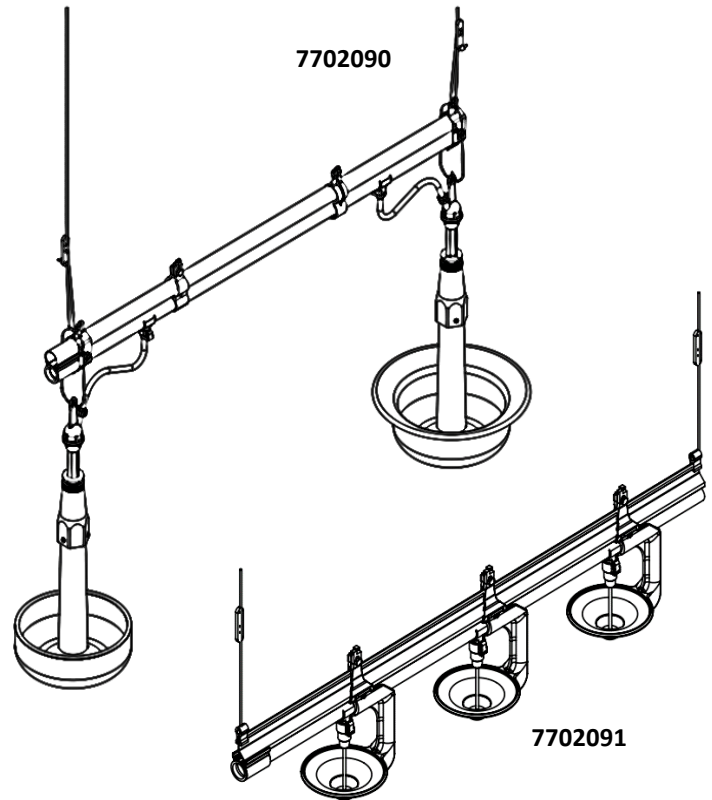
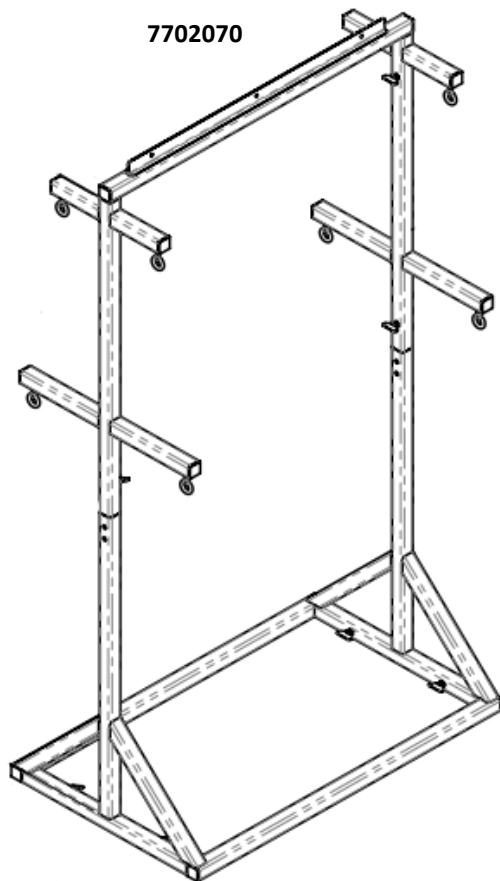

VAL-CO DEALER SAMPLES AND DISPLAYS

Contact your VAL-CO Sales person to inquire about using AgVantage™ funds for displays

Watering - Drinker Kits

CATALOG #	ITEM DESCRIPTION	SHIP WEIGHT		LIST PRICE
		LBS.	KG.	
7701962	Drinker Sample Kit - 12 compartment - Floor Birds and adaptors	2.0	0.9	
7701967	Drinker Sample Kit - 24 compartment - Floor and Cage Birds and adaptors	3.0	1.4	

7701962



7701967



Watering - Drinker Kits

CATALOG #	ITEM DESCRIPTION	SHIP WEIGHT		LIST PRICE
		LBS.	KG.	
820398	Sample Pipe 12" with coupler and (2) saddles	0.2	0.1	
820012	Watering Display - 3' with Flushing intake - Conduit	5.8	2.6	
820189	Watering Display - 3' with Flushing intake - Al Extrusion	9.9		
SMPIPEBTOMSAMP	Sample Big Tom Drinker - Conduit	2.1	0.9	
SMPIPEBTOMALUMSAMP	Sample Big Tom Drinker - Al Extrusion	1.9	0.8	
820624	Sample Big Tom Drinker - Al Extrusion	0.1	0.1	

820398

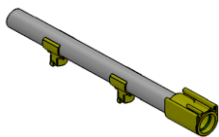

SMPIPEBTOMSAMP

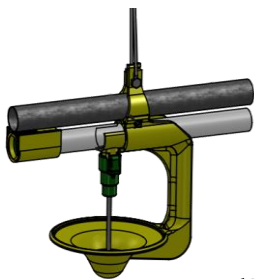

820012

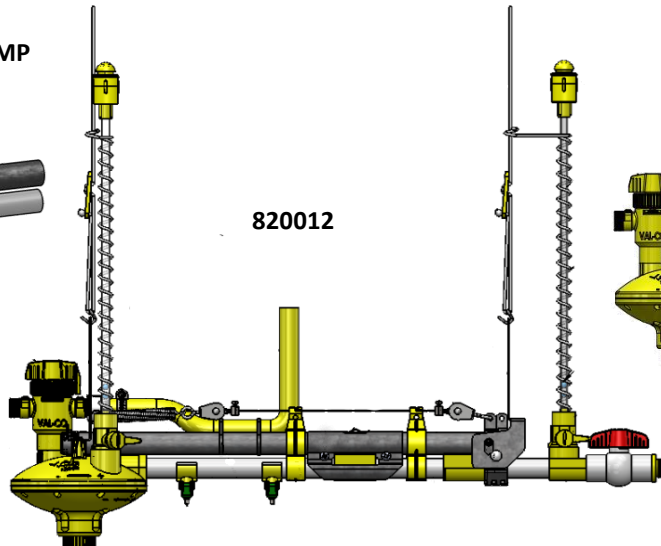

820189

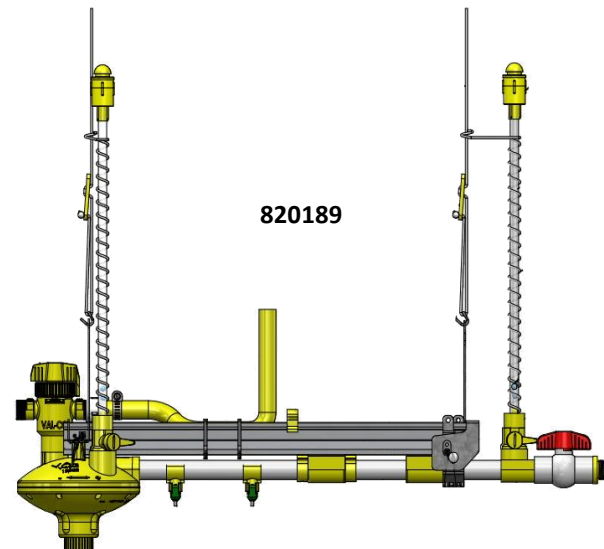

VAL-CO DEALER SAMPLES AND DISPLAYS

Contact your VAL-CO Sales person to inquire about using AgVantage™ funds for displays

Nesting

CATALOG #	ITEM DESCRIPTION	SHIP WEIGHT		LIST PRICE
		LBS.	KG.	
412480	Sidebelt Nest Display - half Comfort Nest & half 10-hole Nest	56.0	25.4	

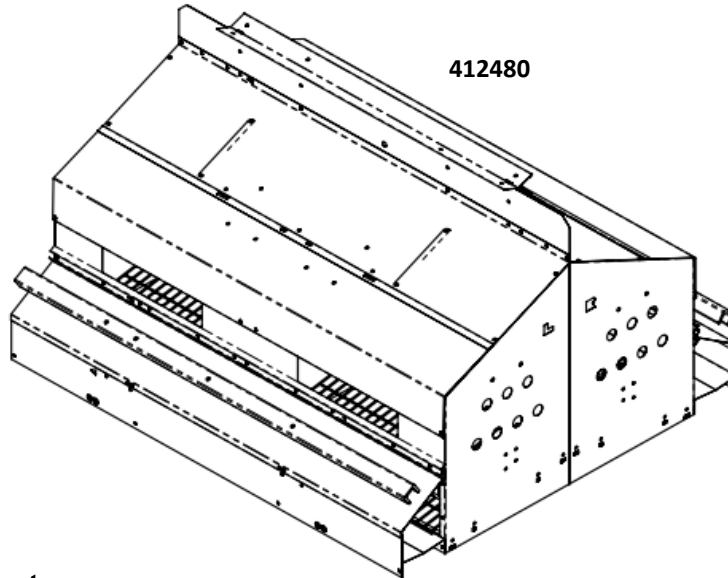

Oasis Cool Cell System

CATALOG #	ITEM DESCRIPTION	SHIP WEIGHT		LIST PRICE
		LBS.	KG.	
813070	Coolpad display - 2' section with pads, sign	39.2	17.8	

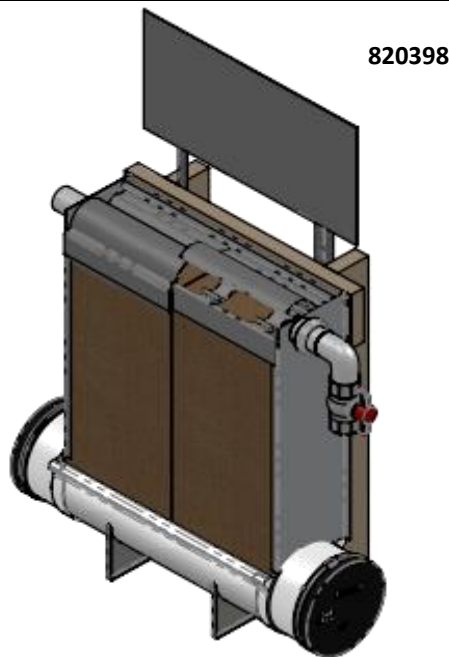

VAL-CO DEALER SAMPLES AND DISPLAYS

Contact your VAL-CO Sales person to inquire about using AgVantage™ funds for displays

Signs

CATALOG #	ITEM DESCRIPTION	SHIP WEIGHT		LIST PRICE
		LBS.	KG.	
690450	Aluminum Sign - "VAL-CO" - 3' x 4'	15.0	6.8	



690450

Flexible Auger Board

CATALOG #	ITEM DESCRIPTION	SHIP WEIGHT		LIST PRICE
		LBS.	KG.	
725452	Flexible Auger Display Board (31" x 48")	63.5	28.8	

