

SECTION 28 FANS

IN THIS CATALOG SECTION

PAGE NUMBER	CONTENTS
28-02	Explanation of Fan Descriptions
28-03	Construction Dimensions
28-04	36" Galvanized & "Z" HYPERMAX Slant Wall Fans & Shutters
28-05	36" Galvanized & "Z" Slant Wall Variable Speed (V-Fan) Direct Drive Fans & Shutters
28-06	48" Galvanized & "Z" HYPERMAX Slant Wall Fans & Shutters
28-07	48" Galvanized & "Z" HYPERMAX Damper Fans
28-08	54" Galvanized & "Z" HYPERMAX Damper Fans
28-09	54" Galvanized HYPERMAX & "Z" Slant Wall Belt Drive 40" Long Cone Fans & Shutters
28-10	54" Galvanized HYPERMAX & "Z" Slant Wall Belt Drive 26" Short Cone Fans & Shutters
28-11	54" Galvanized & "Z" Slant Wall Variable Speed (V-Fan) Direct Drive Fans & Shutters
28-12	12" - 24" PM Fiberglass & Sable Power Miser Direct Drive Fans & Shutters
28-13	36" HYPERMAX Fiberglass & Sable, Direct Drive Fans, Shutters & Cones
28-14	36" HYPERMAX Fiberglass & Sable, Belt Drive Fans, Shutters & Cones
28-15	36" Fiberglass, Direct Drive Variable Speed (V-Fan) Aluminum Blade Fans, Cones & Shutters
28-16	36" Fiberglass, Direct Drive Variable Speed (V-Fan) Galvanized & SS Blade Fans, Cones & Shutters
28-17	50" HYPERMAX Fiberglass & Sable, Belt Drive Fans, Shutters & Cones
28-18	54" HYPERMAX Fiberglass & Sable Single Phase Belt Drive Long Cone Fans & Shutters
28-19	54" HYPERMAX Fiberglass & Sable Three Phase Belt Drive Long Cone Fans & Shutters
28-20	54" HYPERMAX Fiberglass & Sable Belt Drive Short Cone Fans & Shutters
28-21 through 28-25	54" Fiberglass, Direct Drive Variable Speed (V-Fan) Fans & Shutters
28-26	54" HYPERMAX Fiberglass, Belt Drive Exterior Mount Long Cone Fans & Shutters
28-27	MACH 57™ 57" BELT DRIVE DAMPER FANS
28-28	Box Fans
28-29	Horizontal Air Flow Circulating Fans
28-30	Pit Fan Adapters and Elbows
28-31	Winter Doors & Wind Diverters
28-32	Light Trap Kits and Transitions
28-33	Hemisphere® Centrifugal Fans & Acc.
28-34	Hemisphere® Directional Centrifugal Fans, "Z" Pro™ Hemisphere® Mixing Fans & Acc.

General Notice About Fan Test Data In this Catalog: Fan test data in this catalog was determined at BESS Lab utilizing standardized testing protocol which includes aluminum shutters where applicable. Testing has shown that fan performance with vinyl shutters will be reduced relative to the published data.

Notice about knock down "KD" fans: For fans available in KD (unassembled) version must be ordered in quantities of 9 (nine) or more fans. Fans ordered in quantities of 1-8 fans will be automatically shipped assembled, crated, and sold at the assembled fan price.

FANS

EXPLANATION OF FAN DESCRIPTIONS

DESCRIPTION 1: 54" FAN, W-FG, SLTW, AL BLD, ZP, STD	
BLADE DIAMETER HOUSING MATERIAL FAN TYPE BLADE MATERIAL COMP. MATL.	BLADE SPEED
DESCRIPTION 2: 1.5HP, 230V, 1P, 60, WCN, INT	
HORSEPOWER VOLTAGE PHASE FREQUENCY ACCESSORIES MOUNT/QTY.	

HOUSING MATERIAL

GALV	GALVANIZED
W-FG	WHITE FIBERGLASS
B-FG	BLACK FIBERGLASS
BWFG	BLACK INTERIOR FIBERGLASS WHITE EXTERIOR
ZM	Z FAN

COMPONENT MATERIAL

(Motor Mount and Hardware)

ZP	GALVANIZED MOTOR MOUNT ZINC PLATED HARDWARE
SS	STAINLESS STEEL

HORSEPOWER

0.25HP	1/4 HORSEPOWER
0.5HP	1/2 HORSEPOWER
1.0HP	1 HORSEPOWER
1.5HP	1-1/2 HORSEPOWER
2.0HP	2 HORSEPOWER
5.0HP	5 HORSEPOWER

ACCESSORIES

LWG	LESS WIRE GUARD
WWG	WITH WIRE GUARD
LCN	LESS CONE
WCN	WITH CONE
WSC	WITH SHORT CONE (Metal Fan)
WLC	WITH LONG CONE (Metal Fan)
WSC	WHITE SHORT CONE (FG Fan)
WLC	WHITE LONG CONE (FG Fan)
WLP	WHITE LONG POLY (FG Fan)
BSC	BLACK SHORT CONE (FG Fan)

FAN TYPE

SLTW	SLANTWALL
DMPR	DAMPER
BOX	BOX
HEMS	HEMISPHERE®
HAF	HORIZONTAL AIRFLOW

VOLTAGE

115/230V	115/230V AC
*115/*230V	110-115/220-230V AC
208V	208V AC
230V	230V AC
208-230V	208-230V AC
*230/460V	200-230/460V AC or 208-230/460V AC
230/460V	230/460V AC
220V	220V AC
220/380V	220/380V AC
190/380V	190/380V AC

Refer to catalog item for specific fan voltage

MOUNTING, ASSEMBLY, & QUANTITY

INT	INTERIOR MOUNT, ASSEMBLED
EXT	EXTERIOR MOUNT, ASSEMBLED
-KD	KNOCK DOWN - UNASSEMBLED FAN
-Q2	QUANTITY 2 FANS
-Q3	QUANTITY 3 FANS
-Q4	QUANTITY 4 FANS
-Q12	QUANTITY 12 FANS

BLADE MATERIAL

AL	ALUMINUM
GV	GALVANIZED
SS	STAINLESS STEEL
CP	COMPOSITE

BLADE SPEED

HE	HIGH EFFICIENCY
STD	STANDARD
HC	HIGH CAPACITY
DD	DIRECT DRIVE
VAR	VARIABLE SPEED

PHASE

1P	SINGLE PHASE
3P	THREE PHASE

FREQUENCY

50	50 HERTZ
60	60 HERTZ

FANS

CONSTRUCTION DIMENSIONS

(in Inches)

	"A"	"B"	"C"	"D"	"E"	"F"	"G"	"H"
12" PM Fan with Cone	22.75	4.75	18.5	32	18.5	18.5		
16" PM Fan with Cone	27.25	5.5	24	34	23	23		
21" PM Fan with Cone	31	5.5	28.75	35	26.5	26.5		
24" PM Fan with Cone	33	5.5	32	38	29	29		
36" FG fan w/ 936174 cone	48.5	3.75	44.5	47	44.5	44.5		
36" FG fan w/ PC36L(B or W) cone	48.5	7	50.25	47	44.5	44.5		
50" FG fan w/ 950188 cone	62.25	0.25	54.25	37.63	56	58		
50" FG fan w/ PC50S(B or W) cone	62.25	8.5	59	39.25	56	58		
50" FG fan w/ FC50LW cone	62.25	8.5	64.5	49.25	56	58		
54" Interior Mount FG fan with long cone	65	8.25	68.88	65.25	61.5	61.5		
54" Interior Mount FG fan with short cone	65	2.5	61.25	38.87	61.5	61.5		
54" Exterior Mount FG fan with long cone	64.4	8.25	68.88	57			65	65
54" Exterior Mount FG fan with short cone	64.4	2.5	61.25	31.25			65	65
36" Sheet Metal Slant Wall Fan	48.5	7.5	49	47	43.5	44.5		
48" Sheet Metal Slant Wall Fan	59.5	8	59.5	60		55.5		
48" Damper Fan	59	2.5	60.25	51	55.5	55.5		
54" Sheet Metal Slant wall fan w/ 40" Cone	64	11	69	64.5	60	60.25		
54" Sheet Metal Slant wall Fan w/ 26" Cone	64	9	69	51.25	60	60.25		
54" Damper Fan	63.75	4.5	69	55.5	60.25	60.25		
57" Damper Fan	61	5.6	69.5	56	57	57	58.5	58.5

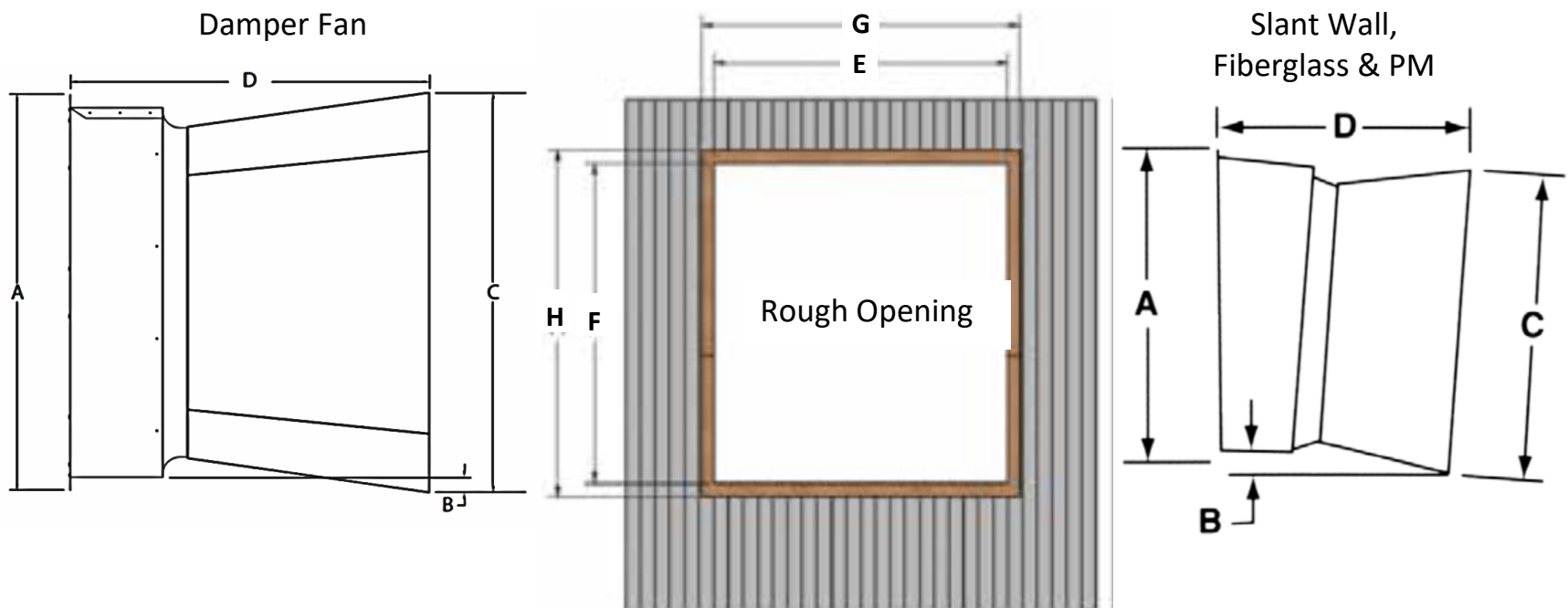

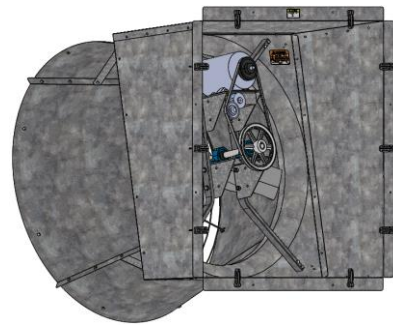

GALVANIZED AND "Z" FAN SERIES 36" HYPERMAX SLANT WALL FANS

HOW TO ORDER

To order a complete 36" HYPERMAX galvanized slant wall fan with cone, select one each **FAN** and one each **SHUTTER** as needed.

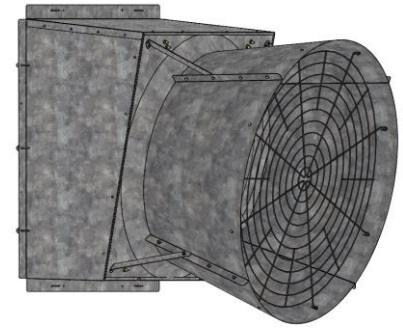

36" HYPERMAX GALV. SLANT WALL FANS WITH CONE, INTERIOR MOUNT - Single Phase Direct Drive

CATALOG NUMBER	Housing	Blade	Motor Mount	Motor / Electric				BESS #	Performance Numbers tested with Aluminum Shutters							SHIP Weight	LIST PRICE EACH	
				HP / RPM	Phase	Hertz	Volts		Amps	@ .00" SP	@ .05" SP	@ .10" SP	@ .15" SP	@ .20" SP	@ .25" SP			@ .30" SP
										CFM	CFM	CFM	CFM	CFM	CFM	CFM		Lbs. / Kg
936200	Galvanized	Galvanized	Galvanized	0.5 / 850	Single Phase	60 Hz	208-230	3.62 Amps @ 230v @ .30" SP	17092	11,410	10,720	10,010	9,210	8,290	6,720	5,020	210 / 95	
936200-Q2										19.4	17.5	15.8	14.0	12.1	9.3	6.4	404 / 183	

36" HYPERMAX SLANT WALL FANS WITH CONE, INTERIOR MOUNT - Single Phase Belt Drive

936150	Galv.	Galvanized	Galvanized	0.5 / 1725	Single Phase	60 Hz	230 Volts	3.65 Amps @ 230v @ .30" SP	17087	12,200	11,240	10,330	8,830	5,430	3,410	990	205 / 93								
936150-KD																									
936150-Q2																									
936150-ZM	Z*	Galvanized	Galvanized	0.5 / 1725	Single Phase	60 Hz	230 Volts	3.65 Amps @ 230v @ .30" SP	17087	22.4	19.4	17.0	13.7	7.7	4.4	1.2	205 / 93								
936150-ZM-Q2																									
936155-ZM	Z*	Aluminum Blade	Galvanized	0.5 / 1725	Single Phase	60 Hz	230 Volts	2.71 Amps @ 230v @ .30" SP	16542	11,620	10,910	10,090	9,310	8,160	6,400	4,500	208 / 94								
936155-ZM-Q2																									
936250	Galvanized	Galvanized	Galvanized	1.5 / 1725	Single Phase	60 Hz	230 Volts	6.17 Amps @ 230v @ .30" SP	17088	16,550	16,070	15,420	14,790	14,080	13,340	12,550	221 / 100								
936250-KD																									
936250-Q2																									

36" HYPERMAX SLANT WALL FANS WITH CONE, INTERIOR MOUNT - Three Phase Belt Drive

936270	Galv.	Galvanized	Galvanized	1.0 / 1725	Three Phase	60 Hz	208-230 / 460 Volts	3.12 Amps @ 230v @ .30" SP	22158	14,510	13,820	13,090	12,430	11,690	10,700	9,080	202 / 92								
936270-KD																									
936270-Q2																									
936270-ZM	Z*	Galvanized	Galvanized	1.0 / 1725	Three Phase	60 Hz	208-230 / 460 Volts	3.12 Amps @ 230v @ .30" SP	22158	17.3	15.8	14.3	13.1	12.0	10.6	8.9	202 / 92								
936270-ZM-Q2																									
936290	Galv.	Galvanized	Galvanized	1.0 / 1425	Three Phase	50 Hz	190/380 Volts	1.74 Amps @ 380v @ .30" SP	22160	14,110	13,430	12,740	11,990	11,180	10,060	7,720	223 / 101								
936290-KD																									
936290-Q2																									
936290-ZM	Z*	Galvanized	Galvanized	1.0 / 1425	Three Phase	50 Hz	190/380 Volts	1.74 Amps @ 380v @ .30" SP	22160	17.3	15.7	14.3	13.0	11.8	10.3	7.8	202 / 92								
936290-ZM-Q2																									
936320-ZM	Z*	Aluminum Blade	Galvanized	1.0 / 1725	Three Phase	60 Hz	208-230 / 460 Volts	2.76 Amps @ 230v @ .30" SP	17090	13,200	12,550	11,980	11,270	10,570	9,620	8,270	203 / 92								
936320-ZM-Q2																									
936340-ZM	Z*	Aluminum Blade	Galv.	1.0 / 1425	Three Phase	50 Hz	190/380 Volts	1.62 Amps @ 230v @ .30" SP	16543	13,360	12,800	12,230	11,570	10,910	10,040	8,910	204 / 93								
936340-ZM-Q2																									

* Z Protective coating used for the fan orifice, housing, and cone. 7 year rust through warranty on housings (Poultry Application).

KD - Knock Down version is an unassembled fan to save space for Shipping

Q2 - Quantity of 2 fans shipped together assembled to save space and money (requires 2 shutters)

Fan Assembly Jig

950160	Knock Down Fixture for Fan Assembly	6.0 / 2.7	
--------	-------------------------------------	-----------	--

36" SHUTTERS

CATALOG NUMBER	ITEM DESCRIPTION	OUTSIDE DIMENSIONS HEIGHT x WIDTH	SHUTTER DIMENSIONS HEIGHT X WIDTH	SHIP WGT.		LIST PRICE
				LBS	KGS	
SPM36W	36" Shutter - White PVC	45.5" x 45.5"	43" x 43"	16.0	7.3	
SPM36B	36" Shutter - Black PVC	45.5" x 45.5"	43" x 43"	16.0	7.3	
SPM36A	36" Shutter - Aluminum	45." x 45."	42" x 42"	20.0	9.1	

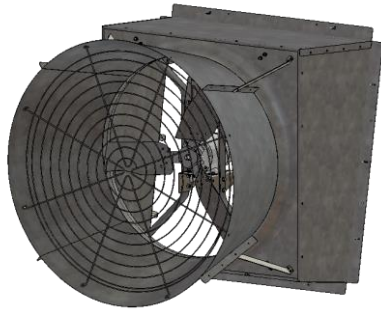

"Z" & GALVANIZED V-FAN SERIES 36" SLANT WALL DIRECT DRIVE V-FANS

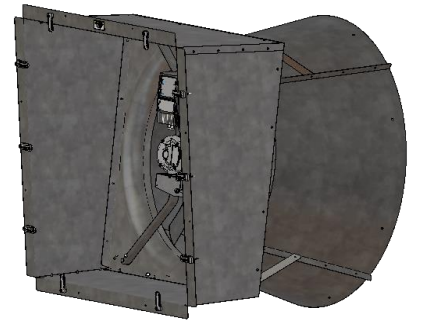

HOW TO ORDER

To order a complete 36" fan, select one each **FAN**, and one each **SHUTTER**.

GALVANIZED BLADE, INTERIOR MOUNT

Catalog Number	Housing	Blade	Motor Mount	Motor	Input Electric				BESS #	Blade Speed	Performance Numbers tested at 230v, 60Hz with Aluminum Shutters								Ship Weight	LIST PRICE EACH				
					Phase	Hertz	Volts	Amps			@ .00" SP	@ .05" SP	@ .10" SP	@ .15" SP	@ .20" SP	@ .25" SP	@ .30" SP							
											RPM	CFM	CFM	CFM	CFM	CFM	CFM	CFM			LBS.			
936260-1	Galvanized	Galvanized	Galvanized	.75 HP	Single Phase 60 Hz / 50 Hz	200-240 Volts	4.95 Amps @ .30" SP	20202	912	11,860	11,370	10,830	10,230	9,590	8,940	8,040	189							
936260-1-Q2												76	26.5	23.6	21.1	18.7	16.5	14.7	12.2	86				
936260-ZM-1	Z Material	Galvanized	Galvanized									780	10,320	9,710	8,990	8,250	7,310	5,480	4,310	363				
936260-ZM-1-Q2												65	34.3	29.7	25.2	21.5	17.7	12.0	8.5	165				
												660	8,780	8,010	7,100	5,960	3,780	2,550	800	189				
												55	44.5	36.1	28.8	22.1	11.8	7.1	2.2	86				
												540	7,100	6,110	4,580	2,100				363				
												45	56.8	43.0	27.6	10.2				165				
936260-3	Galvanized	Galvanized	Galvanized	.75 HP					Single Phase 60 Hz / 50 Hz	200-240 Volts	2.53 Amps @ .30" SP	20199	912	11,830	11,340	10,790	10,210	9,530	8,870	7,960	189			
936260-3-Q2																76	27.0	23.9	21.2	18.8	16.6	14.7	12.5	86
936260-3-KD	Z Material	Galvanized	Galvanized													780	10,340	9,720	8,990	8,200	7,290	5,360	4,140	363
936260-ZM-3																65	34.9	30.1	25.6	21.2	18.1	11.8	8.2	165
936260-ZM-3-Q2								660					8,810	8,060	7,110	5,860	3,810	2,510	1,270	146				
								55					45.6	37.0	28.9	22.3	12.0	7.0	3.2	66				
								540					7,110	6,110	4,380	2,060				189				
								45					58.2	44.0	27.4	9.8				86				
																				363				
																				165				

* Z Protective coating used for the fan orifice, housing, and cone. 7 year rust through warranty on housings (Poultry Application).

Q2 - Quantity of 2 fans shipped together assembled to save space and money (requires 2 shutters)

Fan Assembly Jig

950160	Knock Down Fixture for Fan Assembly	6.0 / 2.7
--------	-------------------------------------	-----------

36" SHUTTERS

CATALOG NUMBER	ITEM DESCRIPTION	OUTSIDE DIMENSIONS HEIGHT x WIDTH	SHUTTER DIMENSIONS HEIGHT X WIDTH	SHIP WEIGHT		LIST PRICE
				LBS.	KGS	
SPM36W	36" Shutter - White PVC	45.5" x 45.5"	43" x 43"	16	7.3	
SPM36B	36" Shutter - Black PVC	45.5" x 45.5"	43" x 43"	16	7.3	
SPM36A	36" Shutter - Aluminum	45." x 45."	42" x 42"	20	9.1	

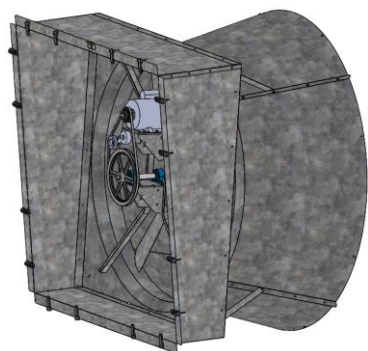

GALVANIZED AND "Z" FAN SERIES - BELT DRIVE 48" HYPERMAX SLANT WALL FANS

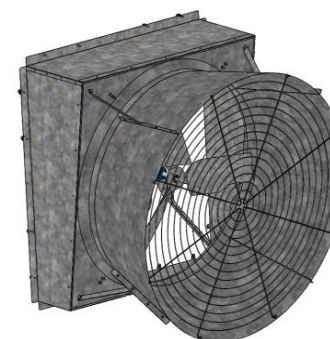

HOW TO ORDER

To order a complete 48" HYPERMAX galvanized slant wall fan with cone,
 select one each **FAN** and one each **SHUTTER** as needed.

48" HYPERMAX SLANT WALL FANS WITH CONE, INTERIOR MOUNT - Single Phase Belt Drive

CATALOG NUMBER	Housing	Blade	Motor Mount	Motor / Electric				BESS #	Performance Numbers tested with Aluminum Shutters							SHIP Weight	LIST PRICE EACH	
				HP / RPM	Phase	Hertz	Volts		Amps	@ .00" SP	@ .05" SP	@ .10" SP	@ .15" SP	@ .20" SP	@ .25" SP			@ .30" SP
										CFM	CFM	CFM	CFM	CFM	CFM	CFM	Lbs. / Kg	
948200	Galvanized	Galvanized	Galvanized	1.5 / 1725	Single	60 Hz	230	5.83 A @ 230V @ .30" SP	12704	25,500	24,400	23,200	21,600	19,900	17,900	15,500	260 / 118	
948200-KD	Galvanized	Galvanized	Galvanized	1.5 / 1725	Single	60 Hz	230	5.83 A @ 230V @ .30" SP	12704	22.4	20.7	19.0	17.2	15.5	13.7	11.6	215 / 98	
HGS48G340MGAT	Galv.	Galvanized	Galvanized	1.5 / 1725	Single	60 Hz	230	6.36 A @ 230V @ .30" SP	12703	26,400	25,200	23,900	22,600	20,900	19,000	16,800	260 / 118	
HGS48G340MGAT-ZM	Z*	Galvanized	Galvanized	1.5 / 1725	Single	60 Hz	230	6.36 A @ 230V @ .30" SP	12703	20.5	20.2	17.7	16.9	15.1	13.3	11.6	260 / 118	
HGS48G340NGAT	Galvanized	Galvanized	Galvanized	1.5 / 1725	Single	60 Hz	230	5.34 A @ 230V @ .30" SP	12705	24,800	23,600	22,200	20,600	18,600	16,300	12,300	260 / 118	
										23.7	21.7	19.8	17.9	15.8	13.5	10.2		

48" HYPERMAX SLANT WALL FANS WITH CONE, INTERIOR MOUNT - Three Phase Belt Drive

HGS48G650LGAT	Galvanized	Galvanized	Galvanized	1.5 / 1725	Three	60 Hz	200-230/460		05208	25,900	24,800	23,500	22,200	20,700	18,900	17,000	260 / 118	
										22.4	20.3	18.2	16.4	14.6	12.9	11.1		

* Z Protective coating used for the fan orifice, housing, and cone. 7 year rust through warranty on housings (Poultry Application).

KD - Knock Down version is an unassembled fan to save space for Shipping

Fan Assembly Jig

950160	Knock Down Fixture for Fan Assembly	6.0 / 2.7	
--------	-------------------------------------	-----------	--

48" SHUTTERS

CATALOG NUMBER	ITEM DESCRIPTION	OUTSIDE DIMENSIONS HEIGHT x WIDTH	SHUTTER DIMENSIONS HEIGHT x WIDTH	SHIP WGHT.		List Price
				LBS.	KGS	
SPM48W	48" Shutter - White PVC	57" x 57"	54.5" x 54.5"	23.0	10.4	
SPM48B	48" Shutter - Black PVC	57" x 57"	54.5" x 54.5"	23.0	10.4	
SPM48A	48" Shutter - Aluminum	57" x 57"	54" x 54"	22.0	10.0	

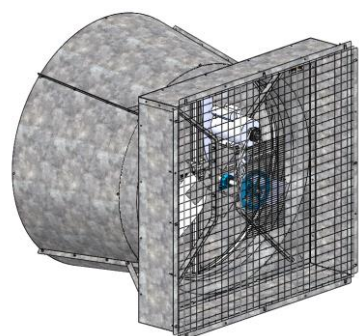

GALVANIZED AND "Z" FAN SERIES - BELT DRIVE 48" HYPERMAX DAMPER FAN SERIES

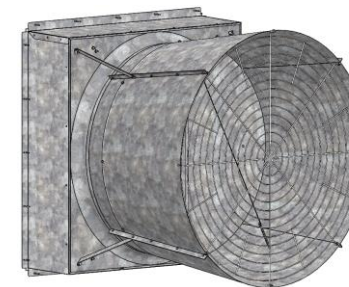

Fan Comes Complete with Damper and Cone

48" DAMPER FANS WITH CONE, INTERIOR MOUNT

CATALOG NUMBER	Housing	Blade	Motor Mount	Motor / Electric				BESS #								SHIP Weight	LIST PRICE EACH	
				HP / RPM	Phase	Hertz	Volts		Amps	@ .00" SP	@ .05" SP	@ .10" SP	@ .15" SP	@ .20" SP	@ .25" SP			@ .30" SP
				CFM	CFM	CFM	CFM		CFM	CFM	CFM	CFM	CFM	CFM	CFM	CFM	Lbs. / Kg	
948320	Galv.	Galvanized	Galvanized	1.5 / 1725	Single Phase	60 Hz	230 Volts	5.99 A @ 230V @ .30" SP	12723	25,600	24,200	22,700	20,900	19,000	17,000	14,900	291 / 132	
948320-KD										21.8	19.8	17.9	16.1	14.2	12.5	10.9	291 / 132	
948320-ZM	Z*																	

* Z Protective coating used for the fan orifice, housing, and cone. 7 year rust through warranty on housings (Poultry Application).

KD - Knock Down version is an unassembled fan to save space for Shipping

Fan Assembly Jig

950160	Knock Down Fixture for Fan Assembly	6.0 / 2.7	
--------	-------------------------------------	-----------	--

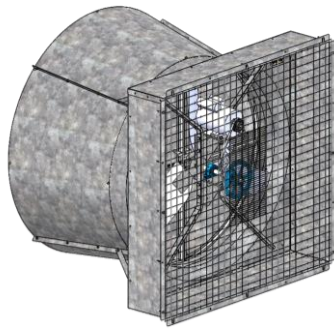

GALVANIZED AND "Z" FAN SERIES - BELT DRIVE 54" HYPERMAX DAMPER FAN SERIES

Fan Comes Complete with Damper and Cone

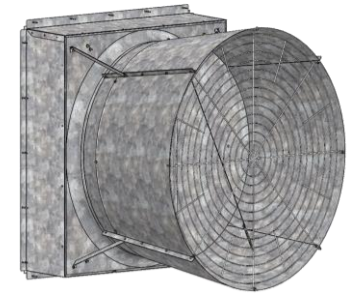

54" DAMPER FANS WITH CONE, INTERIOR MOUNT - Single Phase 60Hz

CATALOG NUMBER	Housing	Blade	Motor Mount	Motor / Electric					BESS #								SHIP Weight	LIST PRICE EACH
				HP / RPM	Phase	Hertz	Volts	Amps		@ .00" SP	@ .05" SP	@ .10" SP	@ .15" SP	@ .20" SP	@ .25" SP	@ .30" SP		
										CFM	CFM	CFM	CFM	CFM	CFM	CFM	Lbs. / Kg	
954430	Galv.	Galvanized	Galvanized	1.5 / 1725	Single Phase	60 Hz	230 Volts	6.22A @ 230V @ .25" SP	17066	29,600	27,700	25,700	23,200	20,700	17,900	14,500	339 / 154	
954430-ZM	Z*	Galvanized	Galvanized	1.5 / 1725	Single Phase	60 Hz	230 Volts	6.22A @ 230V @ .25" SP	17066	23.7	21.1	18.9	17.0	14.8	12.7	10.3	345 / 156	
954440	Galv.	Galvanized	Galvanized	1.5 / 1725	Single Phase	60 Hz	230 Volts	6.82A @ 230V @ .30" SP	17065	30,700	28,900	27,000	24,700	22,300	19,700	16,900	338 / 153	
954440-KD	Galv.	Galvanized	Galvanized	1.5 / 1725	Single Phase	60 Hz	230 Volts	6.82A @ 230V @ .30" SP	17065	30,700	28,900	27,000	24,700	22,300	19,700	16,900	293 / 133	
954440-ZM	Z*	Galvanized	Galvanized	1.5 / 1725	Single Phase	60 Hz	230 Volts	6.82A @ 230V @ .30" SP	17065	23.2	20.8	18.7	16.8	14.8	12.9	11.0	393 / 178	
954500-ZM	Z*	Aluminum	Galv.	1.5 / 1725	Single Phase	60 Hz	230 Volts	5.99A @ 230V @ .25" SP	17064	29,200	27,700	25,600	22,900	20,100	16,500	11,500	351 / 159	
										25.1	22.4	20.0	17.3	14.9	12.1	8.8		

54" DAMPER FANS WITH CONE, INTERIOR MOUNT - Three Phase 60Hz

954460	Galv.	Galvanized	Galvanized	1.5 / 1725	Three Phase	60 Hz	208-230/460	4.99A @ 230V @ .30" SP	17070	31,200	29,500	27,500	25,600	23,300	20,900	18,200	320 / 145	
954460-KD	Galv.	Galvanized	Galvanized	1.5 / 1725	Three Phase	60 Hz	208-230/460	4.99A @ 230V @ .30" SP	17070	31,200	29,500	27,500	25,600	23,300	20,900	18,200	275 / 125	
954460-ZM	Z*	Galvanized	Galvanized	1.5 / 1725	Three Phase	60 Hz	208-230/460	4.99A @ 230V @ .30" SP	17070	23.4	20.8	18.5	16.7	14.7	12.9	11.0	326 / 148	
954460-ZM-KD	Z*	Galvanized	Galvanized	1.5 / 1725	Three Phase	60 Hz	208-230/460	4.99A @ 230V @ .30" SP	17070	23.4	20.8	18.5	16.7	14.7	12.9	11.0	281 / 127	
954550	Galv.	Galvanized	Galvanized	2.0 / 1725	Three Phase	60 Hz	208-230/460	6.43A @ 230V @ .30" SP	-	33,700	32,000	30,400	28,600	26,600	24,300	22,100	335 / 152	
954550-ZM	Z*	Galvanized	Galvanized	2.0 / 1725	Three Phase	60 Hz	208-230/460	6.43A @ 230V @ .30" SP	-	19.2	17.3	15.9	14.5	13.3	11.9	10.8	341 / 155	
954530-ZM	Z*	Aluminum	Galv.	1.5 / 1725	Three Phase	60 Hz	208-230/460	5.39A @ 230V @ .30" SP	17069	33,400	31,000	28,900	26,500	24,100	21,300	18,200	338 / 153	
										21.9	19.4	17.3	15.4	13.7	11.9	10.1		

54" DAMPER FANS WITH CONE, INTERIOR MOUNT - Three Phase 50Hz

954470	Galv.	Galvanized	Galvanized	1.5 / 1425	Three Phase	50 Hz	190/380 Volts	2.38A @ 380V @ .30" SP	17071	28,700	26,800	24,800	22,300	19,800	17,100	13,700	325 / 147	
954470-KD	Galv.	Galvanized	Galvanized	1.5 / 1425	Three Phase	50 Hz	190/380 Volts	2.38A @ 380V @ .30" SP	17071	28,700	26,800	24,800	22,300	19,800	17,100	13,700	280 / 127	
954470-ZM	Z*	Galvanized	Galvanized	1.5 / 1425	Three Phase	50 Hz	190/380 Volts	2.38A @ 380V @ .30" SP	17071	26.0	23.1	20.5	17.8	15.3	12.9	10.3	331 / 150	
954540-ZM	Z*	Aluminum	Galv.	1.5 / 1425	Three Phase	50 Hz	190/380 Volts	2.52A @ 380V @ .25" SP	17072	30,700	28,200	26,000	23,300	20,400	17,400	11,900	338 / 153	
										24.7	21.4	19.0	16.6	14.1	12.1	8.6		

* Z Protective coating used for the fan orifice, housing, and cone. 7 year rust through warranty on housings (Poultry Application).

KD - Knock Down version is an unassembled fan to save space and weight for Shipping

Fan Assembly Jig

950160	Knock Down Fixture for Fan Assembly	6.0 / 2.7
--------	-------------------------------------	-----------

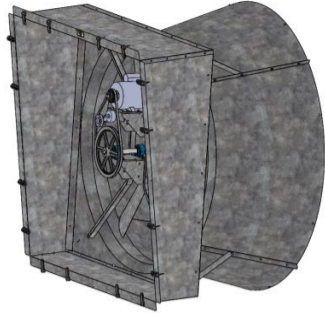

GALVANIZED & "Z" FAN SERIES - BELT DRIVE 54" HYPERMAX SLANT WALL FAN SERIES

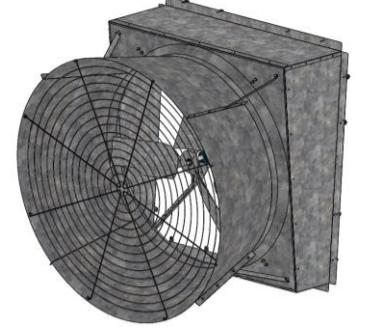

HOW TO ORDER

To order a complete 54" HYPERMAX galvanized slant wall fan with cone,
 Select one each **FAN** and one each **SHUTTER** as needed.

54" HYPERMAX SLANT WALL FANS WITH 40" LONG CONE, INTERIOR MOUNT - Single Phase 60Hz

CATALOG NUMBER	Housing	Blade	Motor Mount	Motor / Electric				BESS #	Performance Numbers tested with Aluminum Shutters							SHIP Weight	LIST PRICE EACH	
				HP / RPM	Phase	Hertz	Volts		Amps	@ .00" SP	@ .05" SP	@ .10" SP	@ .15" SP	@ .20" SP	@ .25" SP			@ .30" SP
										CFM	CFM	CFM	CFM	CFM	CFM	CFM		Lbs. / Kg
954710	Galv.	Galvanized	Galvanized	1.5 / 1725	Single	60 Hz	230 Volts	5.89A @ 230V @ .30" SP	16539	29,900	28,700	27,000	24,700	22,500	19,200	14,100	293 / 133	
954710-ZM	Z*	Galvanized	Galvanized	1.5 / 1725	Single	60 Hz	230 Volts	5.89A @ 230V @ .30" SP	16539	25.5	23.8	21.6	19.1	17.1	14.4	10.5	302 / 137	
954720	Galv.	Galvanized	Galvanized	1.5 / 1725	Single	60 Hz	230 Volts	7.09A @ 230V @ .30" SP	16538	31,800	30,500	29,000	27,100	24,900	22,200	19,100	294 / 133	
954720-ZM	Z*	Galvanized	Galvanized	1.5 / 1725	Single	60 Hz	230 Volts	7.09A @ 230V @ .30" SP	16538	23.3	21.4	19.6	17.7	15.9	13.9	11.9	301 / 137	
954725-ZM	Z*	Aluminum	Galvanized	1.5 / 1725	Single	60 Hz	230 Volts	5.91A @ 230V @ .25" SP	17057	30,800	29,300	27,300	24,800	22,300	19,000	9,900	308 / 140	
										27.4	24.8	22.1	19.2	16.8	14.0	7.3		

54" HYPERMAX SLANT WALL FANS WITH 40" LONG CONE, INTERIOR MOUNT - Three Phase 60Hz

954730	Galv.	Galvanized	Galvanized	1.5 / 1725	Three	60 Hz	208-230 / 460	4.80A @ 230V @ .30" SP	16531	31,900	30,400	29,000	27,100	25,100	22,400	19,100	281 / 127	
954730-ZM	Z*	Galvanized	Galvanized	1.5 / 1725	Three	60 Hz	208-230 / 460	4.80A @ 230V @ .30" SP	16531	24.0	21.9	20.2	18.3	16.5	14.4	12.2	289 / 131	
954735-ZM	Z*	Aluminum	Galvanized	1.5 / 1725	Three	60 Hz	208-230 / 460	4.90A @ 230V @ .30" SP	17056	32,700	31,200	29,400	27,200	24,700	21,900	17,600	295 / 134	
										24.9	22.6	20.4	18.1	16.0	13.9	11.0		
954770	Galv.	Galvanized	Galvanized	2.0 / 1725	Three	60 Hz	208-230 / 460	5.72A @ 230V @ .30" SP	22151	34,100	32,700	31,200	29,800	28,000	25,900	23,600	291 / 132	
954770-ZM	Z*	Galvanized	Galvanized	2.0 / 1725	Three	60 Hz	208-230 / 460	5.72A @ 230V @ .30" SP	22151	20.5	18.7	17.4	16.2	14.8	13.3	11.9	300 / 136	

54" HYPERMAX SLANT WALL FANS WITH 40" LONG CONE, INTERIOR MOUNT - Three Phase 50Hz

954750	Galv.	Galvanized	Galvanized	1.5 / 1425	Three	50 Hz	190 / 380	2.55A @ 380V @ .30" SP	16540	30,200	28,900	27,100	25,400	23,200	20,100	16,000	281 / 127	
954750-KD										23.5	21.9	19.7	18.0	16.1	13.8	11.0	290 / 132	
954750-ZM	Z*	Galvanized	Galvanized	1.5 / 1425	Three	50 Hz	190 / 380	2.55A @ 380V @ .30" SP	16540	23.5	21.9	19.7	18.0	16.1	13.8	11.0	290 / 132	

* Z Protective coating used for the fan orifice, housing, and cone. 7 year rust through warranty on housings (Poultry Application).

KD - Knock Down version is an unassembled fan to save space and weight for Shipping

Fan Assembly Jig

950160	Knock Down Fixture for Fan Assembly	6.0 / 2.7
--------	-------------------------------------	-----------

54" SHUTTERS

CATALOG NUMBER	ITEM DESCRIPTION	OUTSIDE DIMENSIONS HEIGHT x WIDTH	SHUTTER DIMENSIONS HEIGHT X WIDTH	SHIP WEIGHT		LIST PRICE
				LBS	KGS	
SPM54W	54" Shutter - White PVC	61.5" x 61.5"	59" x 59"	34.0	15.4	
SPM54B	54" Shutter - Black PVC	61.5" x 61.5"	59" x 59"	30.0	13.6	
SPM54A	54" Shutter - Aluminum	61.35" x 61.35"	58.25" x 58.25"	38.0	17.2	

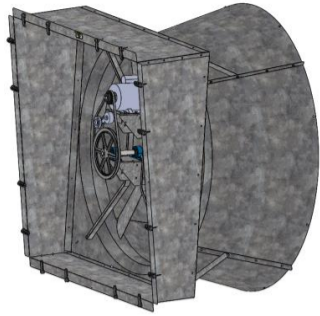

GALVANIZED & "Z" FAN SERIES - BELT DRIVE 54" HYPERMAX SLANT WALL FAN SERIES

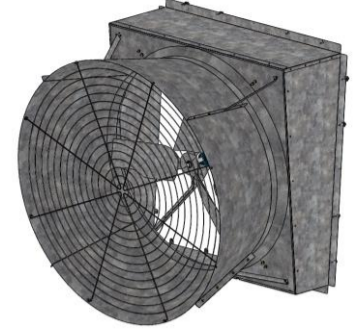

HOW TO ORDER

To order a complete 54" HYPERMAX slant wall fan with cone,
 Select one each **FAN** and one each **SHUTTER** as needed.

54" HYPERMAX SLANT WALL FANS WITH 26" SHORT CONE, INTERIOR MOUNT - Single Phase 60Hz

CATALOG NUMBER	Housing	Blade	Motor Mount	Motor / Electric				BESS #	Performance Numbers tested with Aluminum Shutters							SHIP Weight	LIST PRICE EACH	
				HP / RPM	Phase	Hertz	Volts		Amps	@ .00" SP	@ .05" SP	@ .10" SP	@ .15" SP	@ .20" SP	@ .25" SP			@ .30" SP
										CFM	CFM	CFM	CFM	CFM	CFM	CFM		Lbs. / Kg
954290	Galv.	Galvanized	Galvanized	1.5 / 1725	Single Phase	60 Hz	230 Volts	5.96 Amps @ 230v @ .25" SP	16534	29,700	28,200	26,500	24,600	22,400	19,200	13,900	272 / 123	
954290-KD										CFM/W	CFM/W	CFM/W	CFM/W	CFM/W	CFM/W	CFM/W	CFM/W	CFM/W
954290-ZM	Z*									25.2	22.8	20.8	18.9	16.8	14.1	10.2	281 / 127	
954350	Galv.	Galvanized	Galvanized	1.5 / 1725	Single Phase	60 Hz	230 Volts	7.17 Amps @ 230v @ .30" SP	16535	31,000	29,900	28,100	26,200	24,300	22,000	18,000	273 / 124	
954350-KD										CFM	CFM	CFM	CFM	CFM	CFM	CFM	CFM	CFM
954350-ZM	Z*									22.2	20.6	18.7	17.0	15.5	13.8	11.1	282 / 128	

54" HYPERMAX SLANT WALL FANS WITH 26" SHORT CONE, INTERIOR MOUNT - Three Phase 60Hz

954310	Galv.	Galvanized	Galvanized	1.5 / 1725	Three Phase	60 Hz	208-230 / 460	4.85 Amps @ 230v @ .30" SP	16532	31,200	29,800	28,300	26,300	24,500	22,000	17,900	260 / 118	
954310-KD										CFM	CFM	CFM	CFM	CFM	CFM	CFM	CFM	CFM
954310-ZM	Z*									23.0	21.0	19.4	17.5	15.9	14.1	11.3	269 / 122	

54" HYPERMAX SLANT WALL FANS WITH 26" SHORT CONE, INTERIOR MOUNT - Three Phase 50Hz

954400	Galv.	Galvanized	Galvanized	1.5 / 1425	Three Phase	50 Hz	190 / 380	2.54 Amps @ 380v @ .30" SP	16533	30,100	28,800	26,900	24,900	22,900	20,200	15,800	255 / 116	
954400-KD										CFM	CFM	CFM	CFM	CFM	CFM	CFM	CFM	CFM
954400-ZM	Z*									23.4	21.8	19.6	17.6	16.0	13.9	10.9	264 / 120	
954400-ZM-KD		CFM	CFM	CFM	CFM	CFM	CFM	CFM	CFM	CFM	CFM	CFM	CFM	CFM	CFM	CFM	CFM	224 / 102

* Z Protective coating used for the fan orifice, housing, and cone. 7 year rust through warranty on housings (Poultry Application).

KD - Knock Down version is an unassembled fan to save space and weight for Shipping

Fan Assembly Jig

950160	Knock Down Fixture for Fan Assembly	6.0 / 2.7
--------	-------------------------------------	-----------

54" SHUTTERS

CATALOG NUMBER	ITEM DESCRIPTION	OUTSIDE DIMENSIONS HEIGHT x WIDTH	SHUTTER DIMENSIONS HEIGHT X WIDTH	SHIP WEIGHT		LIST PRICE
				LBS.	KGS	
SPM54W	54" Shutter - White PVC	61.5" x 61.5"	59" x 59"	34.0	15.4	
SPM54B	54" Shutter - Black PVC	61.5" x 61.5"	59" x 59"	30.0	13.6	
SPM54A	54" Shutter - Aluminum	61.35" x 61.35"	58.25" x 58.25"	38.0	17.2	

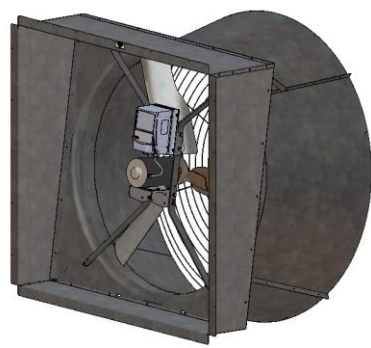

GALVANIZED AND "Z" DIRECT DRIVE FAN SERIES 54" SLANT WALL DIRECT DRIVE V-FANS

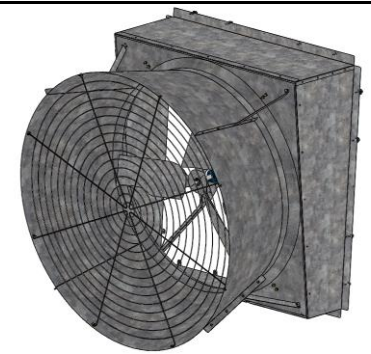

HOW TO ORDER

To order a complete 54" Galvanized or "Z" V-Fan, select one each **FAN**, and one each **SHUTTER**.

54" SLANT WALL V-FANS WITH 26" CONE, INTERIOR MOUNT

CATALOG NUMBER	HOUSING/ BLADE/ MTR MOUNT/ MOTOR		INPUT ELECTRIC				BESS #	BLADE SPEED	Performance Numbers tested at 230v, 60Hz with Aluminum Shutters								SHIP Weight	LIST PRICE EACH						
			Phase	Hertz	Volts	Amps			@ .00" SP		@ .05" SP		@ .10" SP		@ .15" SP				@ .20" SP		@ .25" SP		@ .30" SP	
									RPM	CFM	CFM	CFM	CFM	CFM	CFM	CFM			CFM	CFM	CFM	CFM	CFM	CFM
954260-1	Galvanized	Galvanized Blade	Galvanized Motor Mount	2.0 HP Fan Motor	Single Phase	50/60 Hz	200-240 Volts	5.1 Amps @ .30" SP	22152	602	33,400	32,100	30,800	29,300	27,800	26,000	23,800	272						
954260-ZM-1	Z Material*	Galvanized Blade	Galvanized Motor Mount	2.0 HP Fan Motor	Single Phase	50/60 Hz	200-240 Volts	5.1 Amps @ .30" SP	22152	50 Hz	22.4	20.6	19.0	17.5	16.1	14.6	12.9	281.0						
954260-3	Galvanized	Galvanized Blade	Galvanized Motor Mount	2.0 HP Fan Motor	Three Phase	50/60 Hz	200-240 Volts	5.1 Amps @ .30" SP	22153	602	33,500	32,000	30,800	29,300	27,800	26,000	23,800	272.0						
954260-3-KD																								
954260-ZM-3	Z Material*	Galvanized Blade	Galvanized Motor Mount	2.0 HP Fan Motor	Three Phase	50/60 Hz	200-240 Volts	5.1 Amps @ .30" SP	22153	482	27,400	25,800	23,600	21,400	18,800	13,800	7,000	123.4						
										361	20,300	17,600	14,200	6,000				281.0						
										30 Hz	55.3	44.3	33.5	13.4										
										301	16,500	12,500	4,100					127.5						
										25 Hz	72.6	50.6	14.9											

54" SLANT WALL V-FANS WITH 40" CONE, INTERIOR MOUNT

954705-1	Galvanized	Galvanized Blade	Galvanized Motor Mount	2.0 HP Fan Motor	Single Phase	50/60 Hz	200-240 Volts	12.7 Amps @ .30" SP	19459	602	34,700	33,500	32,200	30,900	29,200	27,300	25,100	293.0	
954705-ZM-1	Z Material*	Galvanized Blade	Galvanized Motor Mount	2.0 HP Fan Motor	Single Phase	50/60 Hz	200-240 Volts	12.7 Amps @ .30" SP	19459	50 Hz	21.9	20.1	18.6	17.4	15.9	14.6	12.9	301.0	
										482	28,400	26,700	24,900	22,700	19,700	16,300	7,200	132.9	
										40 Hz	34.0	30.0	26.0	23.5	19.4	15.8	6.9		
										361	21,000	18,700	15,400	6,400				136.5	
										30 Hz	55.8	49.0	35.7	13.9					
										301	17,100	13,900	4,700					136.5	
										25 Hz	72.8	54.2	17.7						
954705-3	Galvanized	Galvanized Blade	Galvanized Motor Mount	2.0 HP Fan Motor	Three Phase	50/60 Hz	200-240 Volts	6.7 Amps @ .30" SP	19461	599	34,700	33,400	32,100	30,700	29,100	27,100	24,800	293	
954705-3-KD										50 Hz	22.7	21.1	19.0	17.6	16.4	14.7	13.2	133	
										480	28,400	26,600	24,800	22,500	19,500	16,300			
										40 Hz	34.6	29.8	27.0	25.0	19.7	16.2		112	
										359	20,800	18,600	15,300	6,200					
										30 Hz	71.0	57.2	36.4	14.1					
										299	17,000	13,800	4,000					136.5	
										25 Hz	114.0	62.7	16.9						

* Z Protective coating used for the fan orifice, housing, and cone. 7 year rust through warranty on housings (Poultry Application).

KD - Knock Down version is an unassembled fan to save space and weight for Shipping

Fan Assembly Jig

950160	Knock Down Fixture for Fan Assembly	6.0 / 2.7
--------	-------------------------------------	-----------

54" SHUTTERS

CATALOG NUMBER	ITEM DESCRIPTION	OUTSIDE DIMENSIONS HEIGHT x WIDTH	SHUTTER DIMENSIONS HEIGHT X WIDTH	SHIP WEIGHT		LIST PRICE
				LBS.	KGS	
SPM54W	54" Shutter - White PVC	61.5" x 61.5"	59" x 59"	34.0	15.4	
SPM54B	54" Shutter - Black PVC	61.5" x 61.5"	59" x 59"	30.0	13.6	
SPM54A	54" Shutter - Aluminum	61.35" x 61.35"	58.25" x 58.25"	38.0	17.2	

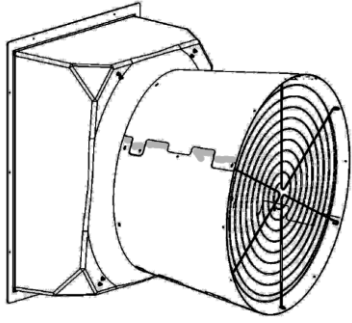

FIBERGLASS PM POWER MISER FAN SERIES 12" - 24" DIRECT DRIVE FANS

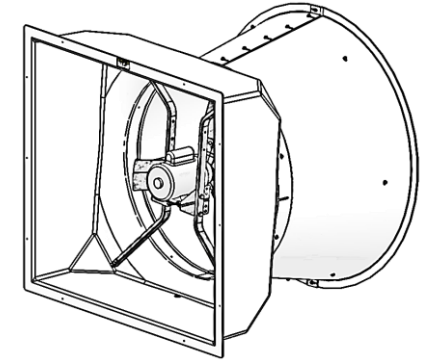

HOW TO ORDER

To order a complete 12 through 24" fiberglass PM fan
 Select one each FAN , one each SHUTTER and one each CONE.

PM FIBERGLASS FANS, INTERIOR MOUNT

CATALOG NUMBER	Housing	Blade	Motor Mount	Motor / Electric				BESS #	Performance Numbers tested with Plastic Shutters							SHIP Weight Lbs. / Kg	LIST PRICE EACH	
				HP / RPM	Phase	Hertz	Volts		Amps	@ .00" SP	@ .05" SP	@ .10" SP	@ .15" SP	@ .20" SP	@ .25" SP			@ .30" SP
										CFM	CFM	CFM	CFM	CFM	CFM			CFM
PM12W140MPA	White	Poly	SS	.25 / 1625	Single	60 Hz	230	.97 A @ .30" SP	-	1,910	1,810	1,720	1,600	1,420	490	420	37 / 17	
PM16W140MPA	White	Poly	Stainless Steel	.25 / 1625	Single Phase	60 Hz	230	1.23A @ 230V @ .30" SP	-	3,050	2,940	2,790	2,620	2,430	2,210	1,890	39 / 18	
PM16W140MPA-BW	Black	Poly	Stainless Steel	.25 / 1625	Single Phase	60 Hz	230	1.23A @ 230V @ .30" SP	-	12.6	11.9	10.9	10.0	9.1	8.1	7.0	39 / 18	
PM21W190LPA	White	Poly	Stainless Steel	0.5 / 850	Single Phase	60 Hz	230	1.19A @ 230V @ .30" SP	23215	5,580	5,390	5,200	4,980	4,780	4,530	4,280	60 / 27	
PM21W190LPA-BW	Black	Poly	Stainless Steel	0.5 / 850	Single Phase	60 Hz	230	1.19A @ 230V @ .30" SP	23215	11.0	10.6	9.9	9.5	8.8	8.3	7.9	54 / 24	
PM24W210MPA	White	Poly	Stainless Steel	0.5 / 1100	Single Phase	60 Hz	230	1.97A @ 230V @ .30" SP	18069	6,480	6,120	5,710	5,230	4,550	2,870	1,300	54 / 24	
PM24W210MPA-BW	Black	Poly	Stainless Steel	0.5 / 1100	Single Phase	60 Hz	230	1.97A @ 230V @ .30" SP	18069	14.1	13.2	12.4	11.4	10.1	6.6	2.8	54 / 24	
924025	W	Poly	Stainless Steel	.5 / 1140	Three Phase	60Hz	230	2.26 A @ .30" SP	23213	7,010	6,720	6,360	5,980	5,510	4,970	3,320	58 / 26	
924025-BW	B									13.3	12.3	11.7	11.0	10.1	9.5	6.8		
924025	W	Poly	Stainless Steel	.5 / 950	Three Phase	50Hz	190	2.15 A @ .30" SP	23214	5,830	5,390	4,930	4,300	2,720	2,220	1,690	58 / 26	
924025-BW	B									17.5	16.2	14.8	12.9	8.6	6.7	4.7		

BW - Sable fan has a White exterior housing and a black interior housing.

PM SHUTTERS

CATALOG NUMBER	ITEM DESCRIPTION	OUTSIDE DIMENSIONS HEIGHT x WIDTH	SHUTTER DIMENSIONS HEIGHT x WIDTH	SHIP WGHT.		LIST PRICE
				LBS	KGS	
SPM12W	PMC 12" Shutter - White PVC	20.0" x 20.0"	17.5" x 17.5"	2.6	1.2	
SPM12B	PMC 12" Shutter - Black PVC			2.6	1.2	
SPM16W	PMC 16" Shutter - White PVC	24.38" x 24.38"	21.87" x 21.87"	4.4	2.0	
SPM16B	PMC 16" Shutter - Black PVC			4.4	2.0	
SPM21W	PMC 21" Shutter - White PVC	28.0" x 28.0"	25.5" x 25.5"	6.8	3.1	
SPM21B	PMC 21" Shutter - Black PVC			5.8	2.6	
SPM24W	PMC 24" Shutter - White PVC	30.25" x 30.25"	27.75" x 27.75"	7.5	3.4	
SPM24B	PMC 24" Shutter - Black PVC			7.6	3.4	

PM POLY CONES

912174	12" Panel Cone, 1 section with grill, White	4.3	2.0	
PC12LW	12" Poly Cone, 1 section with grill, White	8.9	4.0	
PC12LB	12" Poly Cone, 1 section with grill, Black	8.9	4.0	
916174	16" Panel Cone, 2 sections with grill, White	6.5	3.0	
PC16LW	16" Poly Cone, 1 section with grill, White	13.1	5.9	
PC16LB	16" Poly Cone, 1 section with grill, Black	14.0	6.4	
921081	21" Panel Cone, 2 sections with grill, White	7.9	3.6	
PC21LW	21" Poly Cone Kit, with grill, White	18.1	8.2	
PC21LB	21" Poly Cone Kit, with grill, Black	20.0	9.1	
924174	24" Panel Cone, 2 sections with grill, White	9.5	4.3	
PC24LW	24" Poly Cone Kit, with grill, White	22.1	10.0	
PC24LB	24" Poly Cone Kit, with grill, Black	22.4	10.2	
MH94203	Hardware Bag - 12"-24" PM Cones only, SS Hardware- (Already included in with Fans)	0.5	0.2	

Hardware not included with cone kits. Hardware needed for cone kits comes with the fan. If ordering a cone kit without a fan, order a hardware bag separately.

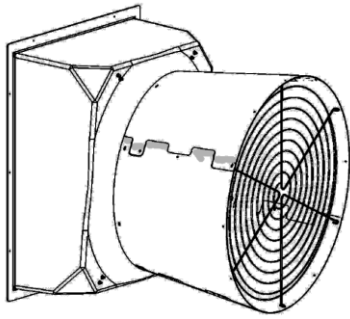

FIBERGLASS FAN SERIES 36" HYPERMAX DIRECT DRIVE FANS

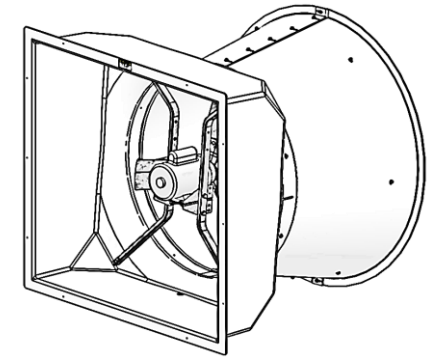

HOW TO ORDER

To order a complete 36" HYPERMAX fiberglass fan,
 Select one each **FAN**, one each **SHUTTER** and one each **CONE** as needed.

HYPERMAX 36" FIBERGLASS FANS, INTERIOR MOUNT

CATALOG NUMBER	Housing	Blade	Motor Mount	Motor / Electric				BESS #	Performance Numbers tested with Aluminum Shutters							SHIP Weight	LIST PRICE EACH							
				HP / RPM	Phase	Hertz	Volts		Amps	@ .00" SP	@ .05" SP	@ .10" SP	@ .15" SP	@ .20" SP	@ .25" SP			@ .30" SP						
										CFM	CFM	CFM	CFM	CFM	CFM	CFM	Lbs. / Kg							
HPM36W280MGA	White FG	Galvanized	Galvanized	0.5 / 850	Single Phase	60 Hz	208-230 Volts	3.39A @ 230V @ .30" SP	17085	11,660	10,840	10,150	9,290	8,140	6,510	4,930	150 / 68							
HPM36W280MGA-Q2																				259 / 117				
HPM36W280MGA-BW	White/Black	Galvanized	Galvanized	0.5 / 850	Single Phase	60 Hz	208-230 Volts	3.39A @ 230V @ .30" SP	17085	20.6	18.1	16.3	14.2	11.9	9.0	6.8	136 / 62							
HPM36W280MGA-BW-Q2																					259 / 117			
HPM36W280MCA	White FG	Aluminum	Stainless Steel	0.5 / 850	Single Phase	60 Hz	208-230	3.24A @ 230V @ .25" SP	18078	11,810	10,880	9,890	8,760	7,250	5,470	3,870	137 / 62							
HPM36W280MCA-Q2																						261 / 118		
HPM36W280MSA	White FG	Stainless Steel	Stainless Steel	0.5 / 850	Single Phase	60 Hz	208-230	3.72A @ 230V @ .30" SP	17086	11,800	11,270	10,480	9,570	8,490	7,060	5,380	136 / 62							
HPM36W280MSA-Q2																							259 / 117	
936350	White FG	Galvanized	Galvanized	1.0 / 850	Single Phase	60 Hz	208-230	3.49A @ 230V @ .30" SP	18081	12,190	11,500	10,730	9,960	8,880	7,580	6,300	138 / 63							
936350-Q2																							263 / 119	
936360-SC	White FG	Stainless Steel	Stainless Steel	1.0 / 850	Single Phase	60 Hz	208-230	3.67A @ 230V @ .30" SP	18080	12,370	11,840	11,120	10,360	9,430	8,470	7,070	138 / 63							
936360-SC-Q2																							263 / 119	
936370	White Fiberglass	Aluminum	Galv.	1.0 / 850	Single Phase	60 Hz	208-230 Volts	3.06A @ 230V @ .25" SP	18079	12,180	11,410	10,570	9,540	8,210	6,580	4,830	139 / 63							
936370-Q2																						265 / 120		
936370-SC																							139 / 63	
936370-SC-Q2																							265 / 120	

SC - Stainless Steel Motor Mount and Hardware

Q2 - Quantity of 2 fans shipped together assembled to save space and money (requires 2 shutters)

BW - Sable fan has a White exterior housing and a black interior housing.

PMC / HYPERMAX 36" SHUTTERS

CATALOG NUMBER	ITEM DESCRIPTION	OUTSIDE DIMENSIONS HEIGHT x WIDTH	SHUTTER DIMENSIONS HEIGHT X WIDTH	SHIP WGHT.		LIST PRICE
				LBS	KGS	
SPM36W	36" Shutter - White PVC	45.5" x 45.5"	43" x 43"	16.0	7.3	
SPM36B	36" Shutter - Black PVC	45.5" x 45.5"	43" x 43"	16.0	7.3	
SPM36A	36" Shutter - Aluminum	45." x 45."	42" x 42"	20.0	9.1	

PMC / HYPERMAX 36" POLY CONES

936174	36" Panel Cone, 4 Sections with Grill - White	19.3	8.8	
PC36LW	36" Poly Cone with Grill - White	33.7	15.3	
PC36LB	36" Poly Cone with Grill - Black	33.7	15.3	
936192	Hardware Bag - 36"-50" Poly & FG Cones, ZP Hardware- (Already included in with Fans)	1.5	0.7	
MH94253	Hardware Bag - 36"-50" Cone Kits only, SS Hardware - (Already included in with Fans)	1.4	0.6	

Hardware not included with cone kits. Hardware needed for cone kits comes with the fan. If ordering a cone kit without a fan, order a hardware bag separately.

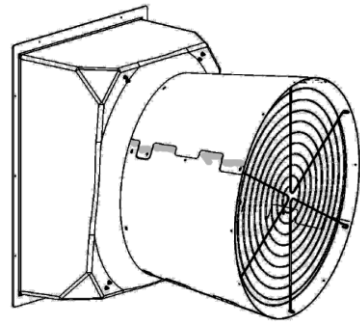

FIBERGLASS FAN SERIES 36" HYPERMAX BELT DRIVE FANS

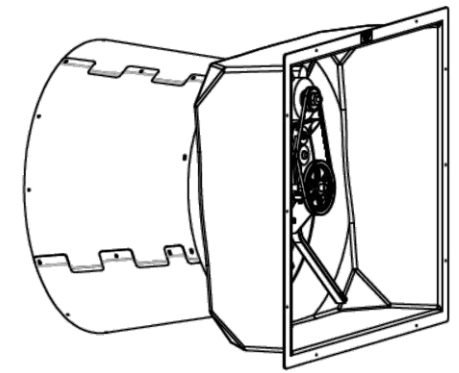

HOW TO ORDER

To order a complete 36" HYPERMAX fiberglass fan,
 Select one each **FAN**, one each **SHUTTER** and one each **CONE** as needed.

HYPERMAX 36" FIBERGLASS FANS, INTERIOR MOUNT

CATALOG NUMBER	Housing	Blade	Motor Mount	Motor / Electric				BESS #	Performance Numbers tested with Aluminum Shutters							SHIP Weight Lbs. / Kg	LIST PRICE EACH	
				HP / RPM	Phase	Hertz	Volts		Amps	@ .00" SP	@ .05" SP	@ .10" SP	@ .15" SP	@ .20" SP	@ .25" SP			@ .30" SP
										CFM	CFM	CFM	CFM	CFM	CFM			CFM
936310	White	Stainless Steel	Stainless Steel	1.5 / 1725	Single Phase	60 Hz	230 Volt	5.93A @ 230V @ .30" SP	17095	16,760	16,080	15,200	14,320	13,320	12,190	10,620	155 / 70	
936310-Q2										14.7	13.7	12.6	11.4	10.3	9.2	7.9	297 / 135	
936315-SC	White	Stainless Steel	Stainless Steel	1.5 / 1725	60 Hz	208-230/460 Volt	4.28A @ 230V @ .30" SP	22123	16,500	15,700	14,930	14,090	13,170	12,030	9,980	157 / 71		
936315-SC-Q2									14.1	13.1	12.0	11.0	10.0	9.0	7.4	300 / 136		
HPM36W340LNAT	White	Aluminum	Galvanized	1.5 / 1725	Single Phase	60 Hz	230 Volt	4.68A @ 230V @ .30" SP	22156	14,520	13,890	13,290	12,680	12,070	11,480	10,790	157 / 71	
HPM36W340LNAT-Q2										15.3	14.2	13.3	12.4	11.6	10.9	10.1	301 / 137	
HPM36W340LGAT	White	Galvanized	Galvanized	1.5 / 1725	Single Phase	60 Hz	230 Volt	6.07A @ 230V @ .30" SP	17096	17,180	16,610	15,840	15,120	14,340	13,420	12,480	155 / 70	
HPM36W340LGAT-Q2										15.9	14.8	13.4	12.3	11.2	10.0	9.0	345 / 156	
936325	White	Galvanized	Galvanized	1.5 / 1725	Three Phase	60 Hz	208-230/460 Volt	4.39A @ 230V @ .30" SP	23212	16,830	16,290	15,610	14,890	14,100	13,250	12,300	155 / 70	
936325-Q2																		
936325-BW	Black	Galvanized	Galvanized	1.5 / 1725	Three Phase	60 Hz	208-230/460 Volt	4.39A @ 230V @ .30" SP	23212	15.7	14.6	13.4	12.2	11.1	10.1	9.0	140 / 64	
936325-BW-Q2																		
HPM36W600LNAT	White	Aluminum	Galvanized	1.0 / 1725	Three Phase	60 Hz	230 / 460 Volts	3.14A @ 230V @ .30" SP	22154	14,320	13,690	13,130	12,460	11,870	11,210	10,510	170 / 77	
HPM36W600LNAT-Q2																		
HPM36W600LNAT-BW	Black	Aluminum	Galvanized	1.0 / 1725	Three Phase	60 Hz	230 / 460 Volts	3.14A @ 230V @ .30" SP	22154								154 / 70	
HPM36W600LNAT-BW-Q2																		
HPM36W600LCAT	White	Aluminum	Stainless	1.0 / 1725	Three Phase	60 Hz	230 / 460 Volts	3.14A @ 230V @ .30" SP	22154	16.0	14.7	13.8	12.8	11.9	11.0	10.2	144 / 65	
HPM36W600LCAT-Q2																		
HPM36W760MGAT	White	Galvanized	Galvanized	0.5 / 1725	Single Phase	60 Hz	230 Volt	3.68A @ 230V @ .29" SP	17093	12,680	11,670	10,480	8,650	5,200	3,380	1050*	141 / 64	
HPM36W760MGAT-Q2										23.6	20.2	17.0	13.1	7.4	4.3	1.3*	270 / 122	
HPM36W760MNAT	White	Aluminum	Galv.	0.5 / 1725	Single Phase	60 Hz	230 Volts	2.51A @ 230V @ .25" SP	17094	11,530	10,520	9,550	8,520	7,090	4,830	3,250	144 / 65	
HPM36W760MNAT-Q2																		
HPM36W760MCAT	Black	Aluminum	SS	0.5 / 1725	Single Phase	60 Hz	230 Volts	2.51A @ 230V @ .25" SP	17094								144 / 65	
HPM36W760MCAT-Q2																		
HPM36W760MNAT-BW	Black	Aluminum	Galvanized	0.5 / 1725	Single Phase	60 Hz	230 Volts	2.51A @ 230V @ .25" SP	17094	21.5	19.0	16.7	14.5	12.0	8.3	5.7	143 / 65	
HPM36W760MNAT-BW-Q2																		

* - tested @ .29" Static Pressure

BW - Sable fan has a White exterior housing and a black interior housing.

Q2 - Quantity of 2 fans shipped together assembled to save space and money (requires 2 shutters)

PMC / HYPERMAX 36" SHUTTERS

CATALOG NUMBER	ITEM DESCRIPTION	OUTSIDE DIMENSIONS HEIGHT x WIDTH	SHUTTER DIMENSIONS HEIGHT X WIDTH	SHIP WGT.		LIST PRICE
				LBS	KGS	
SPM36W	36" Shutter - White PVC	45.5" x 45.5"	43" x 43"	16.0	7.3	
SPM36B	36" Shutter - Black PVC	45.5" x 45.5"	43" x 43"	16.0	7.3	
SPM36A	36" Shutter - Aluminum	45." x 45."	42" x 42"	20.0	9.1	

PMC / HYPERMAX 36" POLY CONES

936174	36" Panel Cone, 4 Sections with Grill - White	19.3	8.8	
PC36LW	36" Poly Cone with Grill - White	33.7	15.3	
PC36LB	36" Poly Cone with Grill - Black	33.7	15.3	
936192	Hardware Bag - 36"-50" Poly & FG Cones, ZP Hardware- (Already included in with Fans)	1.5	0.7	
MH94253	Hardware Bag - 36"-50" Cone Kits only, SS Hardware - (Already included in with Fans)	1.4	0.6	

Hardware not included with cone kits. Hardware needed for cone kits comes with the fan. If ordering a cone kit without a fan, order a hardware bag separately.

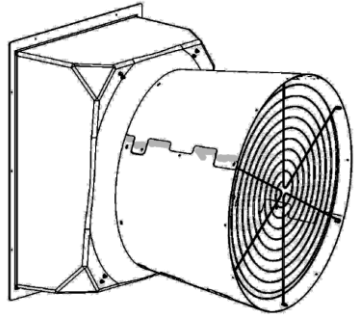

FIBERGLASS V-FAN SERIES

36" SLANT WALL DIRECT DRIVE V-FANS

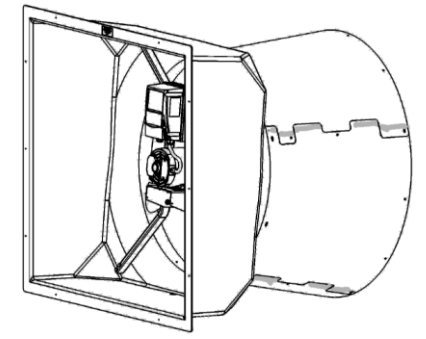

HOW TO ORDER

To order a complete 36" Hypermax fiberglass fan, select one **FAN**, one **CONE** & one **SHUTTER**.

ALUMINUM BLADE, INTERIOR MOUNT

CATALOG NUMBER	Housing	Blade	Mtr Mount	Motor	INPUT ELECTRIC				BESS #	BLADE SPEED	Performance Numbers tested at 230v, 60Hz with Aluminum Shutters							SHIP Weight	LIST PRICE EACH																		
					Phase	Hertz	Volts	Amps			@ .00" SP	@ .05" SP	@ .10" SP	@ .15" SP	@ .20" SP	@ .25" SP	@ .30" SP																				
											RPM	CFM	CFM	CFM	CFM	CFM	CFM			CFM	CFM	LBS.															
Hz	CFM/W	CFM/W	CFM/W	CFM/W	CFM/W	CFM/W	CFM/W	CFM/W	CFM/W	CFM/W	KGS																										
936230-1	White Fiberglass	Aluminum Blade	Galvanized	.75 HP Fan Motor	Single Phase	50 / 60 Hz	200-240 Volts	7.45 Amps @ .30" SP	20192	1140	15,250	14,610	14,050	13,370	12,730	12,040	11,300	139																			
95 Hz										17.1	15.8	14.8	13.7	12.7	11.8	10.9	63																				
1020										13,430	12,790	12,150	11,420	10,650	9,810	8,640	300																				
85 Hz										20.8	19.1	17.5	16.0	14.6	13.2	11.7	136																				
936230-SC-1		Aluminum Blade	SS							.75 HP Fan Motor	Single Phase	50 / 60 Hz	200-240 Volts	7.45 Amps @ .30" SP	20192	840	10,970	10,190	9,340	8,400	7,040	5,370	3,540	139													
70 Hz																29.5	26.1	23.0	20.0	16.8	12.9	8.7	63														
936230-SC-1-Q2		Aluminum Blade	SS													.75 HP Fan Motor	Single Phase	50 / 60 Hz	200-240 Volts	7.45 Amps @ .30" SP	20192	660	8,460	7,390	5,950	3,750	1,840			264							
55 Hz																						45.2	36.2	27.9	17.6	8.7			120								
936230-BW-1	Black/White	Galvanized	.75 HP Fan Motor	Single Phase	50 / 60 Hz	200-240 Volts	7.45 Amps @ .30" SP	20192	540													6,600	5,160	2,350					139								
45 Hz									56.9													41.2	18.7					63									
936230-BW-1-Q2	Black/White	Galvanized							.75 HP Fan Motor													Single Phase	50 / 60 Hz	200-240 Volts	7.45 Amps @ .30" SP	20192									264		
																																				120	
936230-3	White Fiberglass	Aluminum Blade								Galvanized	.75 HP Fan Motor	Three Phase	50 / 60 Hz	200-240 Volts	3.89 Amps @ .30" SP												20193	1140	15,260	14,620	13,970	13,320	12,630	12,060	11,290	139	
95 Hz																												17.4	16.0	14.7	13.8	12.7	11.9	11.0	63		
1020																13,440	12,790	12,070	11,400	10,680	9,840							8,640	264								
85 Hz																21.1	19.2	17.6	16.1	14.7	13.3							11.8	120								
936230-SC-3		Aluminum Blade	Stainless Steel	.75 HP Fan Motor	Three Phase	50 / 60 Hz	200-240 Volts	3.89 Amps @ .30" SP		20193						840	10,980	10,230	9,370	8,340	6,950							5,410	3,580	139							
70 Hz																29.8	26.5	23.2	19.8	16.5	12.9							8.9	63								
936230-SC-3-Q2		Aluminum Blade	Stainless Steel						.75 HP Fan Motor							Three Phase	50 / 60 Hz	200-240 Volts	3.89 Amps @ .30" SP	20193	660	8,290	7,420	6,020	3,760	1,830				164							
55 Hz																					43.0	35.3	28.5	17.9	8.7				74								
936230-BW-SC-3	Black/White	Galvanized	.75 HP Fan Motor								Three Phase	50 / 60 Hz	200-240 Volts	3.89 Amps @ .30" SP	20193						540	6,510	5,290	2,370					140								
45 Hz																					53.3	43.4	19.4					64									
936230-BW-SC-3-Q2	Black/White	Galvanized																			.75 HP Fan Motor	Three Phase	50 / 60 Hz	200-240 Volts	3.89 Amps @ .30" SP	20193									266		
																																				121	
936230-BW-3	Black/White	Galvanized		.75 HP Fan Motor	Three Phase	50 / 60 Hz	200-240 Volts	3.89 Amps @ .30" SP		20193																									139		
																																				63	
936230-BW-3-Q2	Black/White	Galvanized							.75 HP Fan Motor							Three Phase	50 / 60 Hz	200-240 Volts	3.89 Amps @ .30" SP	20193															264		
																																				120	

SC - Stainless Steel Motor Mount and Hardware

Q2 - Quantity of 2 fans shipped together assembled to save space and money (requires 2 shutters and 2 cones)

BW - Sable fan has a White exterior housing and a black interior housing.

PMC / HYPERMAX 36" SHUTTERS

CATALOG NUMBER	ITEM DESCRIPTION	OUTSIDE DIMENSIONS HEIGHT x WIDTH	SHUTTER DIMENSIONS HEIGHT X WIDTH	SHIP WEIGHT		LIST PRICE
				LBS.	KGS	
SPM36W	36" Shutter - White PVC	45.5" x 45.5"	43" x 43"	16.0	7.3	
SPM36B	36" Shutter - Black PVC	45.5" x 45.5"	43" x 43"	16.0	7.3	
SPM36A	36" Shutter - Aluminum	45." x 45."	42" x 42"	20.0	9.1	

PMC / HYPERMAX 36" CONES

936174	36" Panel Cone, 4 Sections with Grill - White			19.3	8.8	
PC36LW	36" Poly Cone with Grill - White			33.7	15.3	
PC36LB	36" Poly Cone with Grill - Black			33.7	15.3	
936192	Hardware Bag - 36"-50" Poly & FG Cones, ZP Hardware- (Already included in with Fans)			1.5	0.7	
MH94253	Hardware Bag - 36"-50" Cone Kits only, SS Hardware - (Already included in with Fans)			1.4	0.6	

Hardware not included with cone kits. Hardware needed for cone kits comes with the fan. If ordering a cone kit without a fan, order a hardware bag separately.

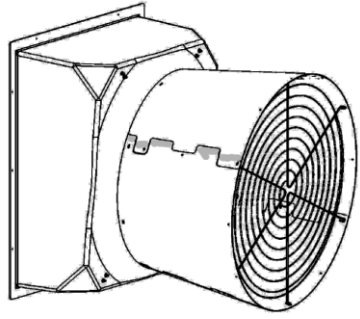

FIBERGLASS V-FAN SERIES

36" SLANT WALL DIRECT DRIVE V-FANS

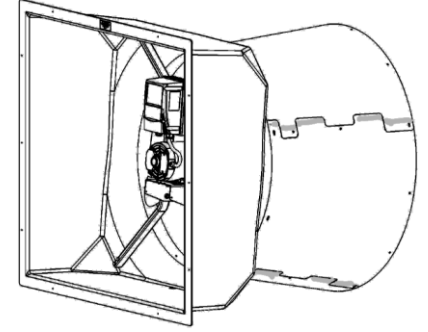

HOW TO ORDER

To order a complete 36" Hypermax fiberglass fan, select one **FAN**, one **CONE** & one **SHUTTER**.

GALVANIZED BLADE, INTERIOR MOUNT

CATALOG NUMBER	Housing	Blade	Mtr Mount	Motor	INPUT ELECTRIC			BESS #	BLADE SPEED	Performance Numbers tested at 230v, 60Hz with Aluminum Shutters								SHIP Weight	LIST PRICE EACH									
					Phase	Hertz	Volts			Amps	@ .00" SP		@ .05" SP		@ .10" SP		@ .15" SP			@ .20" SP		@ .25" SP		@ .30" SP				
											RPM	CFM	CFM	CFM	CFM	CFM	CFM			CFM	CFM	CFM	CFM	CFM	CFM	CFM	CFM	CFM
936235-1	White Fiberglass	Galvanized Blade	Galvanized Motor Mount	.75 HP Fan Motor	Single Phase	50 / 60 Hz	200-240 Volts	4.86 Amps @ .30" SP	20190	912	12,300	11,580	10,940	10,180	9,440	8,480	7,250	136.6										
76 Hz										29.1	24.8	21.7	18.6	16.1	13.7	11.2												
780										10,480	9,750	9,020	8,080	6,780	5,330	4,130	28.1											
65 Hz										36.7	30.4	25.6	20.8	16.3	11.7	7.9												
936235-1-Q2										White Fiberglass	Galvanized Blade	Galvanized Motor Mount	.75 HP Fan Motor	Single Phase	50 / 60 Hz	200-240 Volts	4.86 Amps @ .30" SP	20190	660	8,900	8,020	6,960	5,310	3,710	2,510	990	259.0	
55 Hz																			47.3	37.1	28.1	19.3	11.6	6.8	2.5			
540	7,200	5,940	4,020	2,190				53.3																				
45 Hz	61.5	41.3	23.7	10.3																								
936235-3	White Fiberglass	Galvanized Blade	Galvanized Motor Mount	.75 HP Fan Motor	Single Phase	50 / 60 Hz	200-240 Volts	2.51 Amps @ .30" SP	20195										912	12,250	11,660	10,980	10,260	9,490	8,650	7,400	137.0	
76 Hz																			29.0	25.5	22.2	19.2	16.3	14.0	11.5			
780										10,550	9,820	9,030	8,070	6,990	5,400	4,250	28.2											
65 Hz										37.4	31.0	25.6	20.8	17.1	12.0	8.3												
936235-3-Q2										White Fiberglass	Galvanized Blade	Galvanized Motor Mount	.75 HP Fan Motor	Three Phase	50 / 60 Hz	200-240 Volts	2.51 Amps @ .30" SP	20195	660	8,950	8,050	7,080	5,350	3,760	2,570	950	137.0	
55 Hz																			46.4	37.6	28.6	19.6	11.9	7.0	2.3			
540	7,110	6,030	4,180	2,130				28.2																				
45 Hz	57.8	43.0	25.2	10.1																								

STAINLESS STEEL BLADE, INTERIOR MOUNT

936600-SC-1	White Fiberglass	Stainless Steel Blade	Stainless Steel Motor Mount	.75 HP Fan Motor	Single Phase	50 / 60 Hz	200-240 Volts	5.23 Amps @ .30" SP	20191	912	12,270	11,680	11,030	10,370	9,600	8,900	7,930	138.8										
76 Hz										28.4	24.5	21.2	18.1	15.7	13.5	11.3												
780										10,450	9,810	9,040	8,130	7,230	5,720	3,950	28.6											
65 Hz										35.9	29.9	24.9	20.1	16.4	12.0	7.6												
936600-SC-1-Q2										White Fiberglass	Stainless Steel Blade	Stainless Steel Motor Mount	.75 HP Fan Motor	Single Phase	50 / 60 Hz	200-240 Volts	5.23 Amps @ .30" SP	20191	660	8,810	8,010	6,970	5,740	3,750	2,470	1,520	262.0	
55 Hz																			46.4	36.1	27.1	20.1	11.7	6.8	3.8			
540	7,150	5,970	4,080	2,120				53.9																				
45 Hz	61.1	41.7	23.5	10.3																								
936600-SC-3	White Fiberglass	Stainless Steel Blade	Stainless Steel Motor Mount	.75 HP Fan Motor	Three Phase	50 / 60 Hz	200-240 Volts	2.68 Amps @ .30" SP	20194										912	12,190	11,730	11,090	10,380	9,650	8,930	8,030	138.0	
76 Hz																			27.8	24.7	21.5	18.4	15.9	13.7	11.5			
780										10,520	9,810	8,960	8,090	7,210	5,840	4,060	28.4											
65 Hz										37.3	30.7	24.6	20.1	16.4	12.3	8.0												
936600-SC-3-Q2										White Fiberglass	Stainless Steel Blade	Stainless Steel Motor Mount	.75 HP Fan Motor	Three Phase	50 / 60 Hz	200-240 Volts	2.68 Amps @ .30" SP	20194	660	8,820	7,990	6,980	5,730	3,850	2,520	1,520	262.0	
55 Hz																			46.7	37.0	28.3	20.3	13.6	7.9	3.9			
540	7,130	5,960	4,210	2,220				53.9																				
45 Hz	58.0	42.6	23.9	10.5																								

SC - Stainless Steel Motor Mount and Hardware

Q2 - Quantity of 2 fans shipped together assembled to save space and money (requires 2 shutters & 2 cones)

PMC / HYPERMAX 36" SHUTTERS

CATALOG NUMBER	ITEM DESCRIPTION	OUTSIDE DIMENSIONS HEIGHT x WIDTH	SHUTTER DIMENSIONS HEIGHT x WIDTH	SHIP WEIGHT		LIST PRICE
				LBS.	KGS	
SPM36W	36" Shutter - White PVC	45.5" x 45.5"	43" x 43"	16.0	7.3	
SPM36B	36" Shutter - Black PVC	45.5" x 45.5"	43" x 43"	16.0	7.3	
SPM36A	36" Shutter - Aluminum	45.5" x 45.5"	42" x 42"	20.0	9.1	

PMC / HYPERMAX 36" POLY CONES

936174	36" Panel Cone, 4 Sections with Grill - White			19.3	8.8	
PC36LW	36" Poly Cone with Grill - White			33.7	15.3	
PC36LB	36" Poly Cone with Grill - Black			33.7	15.3	
936192	Hardware Bag - 36"-50" Poly & FG Cones, ZP Hardware- (Already included in with Fans)			1.5	0.7	
MH94253	Hardware Bag - 36"-50" Cone Kits only, SS Hardware - (Already included in with Fans)			1.4	0.6	

Hardware not included with cone kits. Hardware needed for cone kits comes with the fan. If ordering a cone kit without a fan, order a hardware bag separately.

FIBERGLASS FAN SERIES

50" HYPERMAX BELT DRIVE FANS

HOW TO ORDER

To order a complete 50" Hypermax fiberglass fan,
 Select one each **FAN**, one each **SHUTTER** and one each **CONE** as needed.

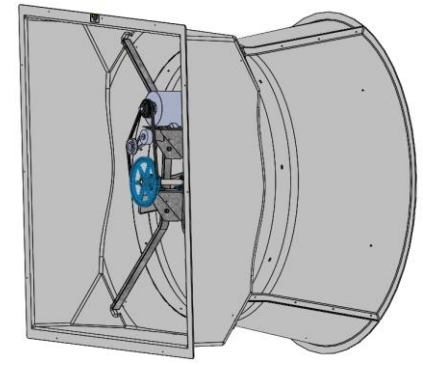

HYPERMAX 50" FIBERGLASS FANS, INTERIOR MOUNT

Single Phase

CATALOG NUMBER	Housing	Blade	Motor Mount	Motor / Electric				BESS #	Performance Numbers tested with Aluminum Shutters							SHIP Weight Lbs. / Kg	LIST PRICE EACH	
				HP / RPM	Phase	Hertz	Volts		Amps	@ .00" SP	@ .05" SP	@ .10" SP	@ .15" SP	@ .20" SP	@ .25" SP			@ .30" SP
										CFM	CFM	CFM	CFM	CFM	CFM			CFM
HPM50W340MCAT-BW	W/B	Aluminum	SS	1.5 / 1725	Single Phase	60 Hz	230 Volt	5.05A @ 230V @ .30" SP	22126	22,900	21,600	20,100	18,600	16,700	11,000	8,400	158 / 72	
HPM50W340MCAT	White FG	Aluminum	Galv.							22.7	20.8	18.8	17.0	15.0	10.2	7.3	197 / 89	
HPM50W340MNAT	White FG	Aluminum	Galv.							22.7	20.8	18.8	17.0	15.0	10.2	7.3	197 / 89	
HPM50W420LCAT	White FG	Aluminum	SS	1.5 / 1725	Single Phase	60 Hz	230 Volt	5.71A @ 230V @ .25" SP	22125	24,500	23,100	21,700	20,300	18,400	16,300	11,000	197 / 89	
HPM50W420LNAT	White FG	Aluminum	Galv.							21.1	18.9	17.6	15.7	14.1	12.5	8.5	197 / 89	
HPM50W420LNAT-BW	W/B	Aluminum	Galv.							21.1	18.9	17.6	15.7	14.1	12.5	8.5	197 / 89	
950140-SSHW	White FG	Aluminum	SS	1.5 / 1725	Single Phase	60 Hz	230 Volt	6.38A @ 230V @ .25" SP	22385	25,500	24,200	22,900	21,500	19,900	18,100	13,900	156 / 71	
950140	White FG	Aluminum	Galv.							19.6	18.0	16.6	15.3	13.9	12.5	9.8	157 / 71	
950140-BW	W/B	Aluminum	Galv.							19.6	18.0	16.6	15.3	13.9	12.5	9.8	157 / 71	
HPM50W340MSAT	White FG	Stainless Steel	Stainless Steel	1.5 / 1725	Single Phase	60 Hz	230 Volt	5.70A @ 230V @ .30" SP	22124	24,500	23,100	21,600	20,100	18,500	16,500	10,500	190 / 86	
	White FG	Stainless Steel	Stainless Steel							23.2	20.9	18.7	16.5	14.7	13.0	8.0		

Three Phase

HPM50W600MCAT	White FG	Aluminum	SS	1.0 / 1725	Three Phase	60 Hz	208-230/460 Volt	3.29A @ 230V @ .30" SP	22133	22,700	21,200	19,600	18,000	16,000	10,500	7,500	185 / 84	
HPM50W600MNAT	White FG	Aluminum	Galv.							24.3	21.9	19.4	17.5	15.4	10.4	6.9	185 / 84	
HPM50W600MNAT-BW	W/B	Aluminum	Galv.							24.3	21.9	19.4	17.5	15.4	10.4	6.9	185 / 84	
950225	White FG	Aluminum	Galv.	1.5 / 1725	Three Phase	60 Hz	208-230/460 Volt	4.87A @ 230V @ .30" SP	22131	26,300	25,000	23,700	22,300	21,000	19,400	17,300	149 / 68	
950225-SSHW	White FG	Aluminum	SS							18.3	16.9	15.6	14.4	13.3	12.1	10.8	153 / 69	
950255	White FG	Aluminum	Galvanized	2.0 / 1725	Three Phase	60 Hz	208-230/460 Volt	5.94A @ 230V @ .30" SP	22135	28,800	27,600	26,400	25,200	24,000	22,500	20,900	157 / 71	
950255-BW	W/B	Aluminum	Galvanized							15.4	14.3	13.4	12.5	11.7	10.8	10.0	161 / 73	
950235	White FG	Aluminum	Galv.	1.5 / 1725	Three Phase	50 Hz	190/380 Volt	2.54A @ 380V @ .25" SP	22132	25,100	23,700	22,300	21,000	19,300	17,300	12,200	145 / 66	
950235-SSHW	White FG	Aluminum	SS							19.7	17.8	16.4	15.1	13.6	12.1	8.9	145 / 66	

BW - Sable fan has a White exterior housing and a black interior housing (Housing W/B).

SSHW - Stainless Steel Motor Mount & Hardware

HYPERMAX 50" SHUTTERS

CATALOG NUMBER	ITEM DESCRIPTION	OUTSIDE DIMENSIONS HEIGHT x WIDTH	SHUTTER DIMENSIONS HEIGHT X WIDTH	SHIP WGHT.		LIST PRICE
				LBS	KGS	
SPM50W	PMC 50" Shutter - White PVC	59.18" x 57"	56.4" x 54.13"	27.0	12.2	
SPM50B	PMC 50" Shutter - Black PVC	59.18" x 57"	56.4" x 54.13"	26.0	11.8	
SPM50A	PMC 50" Shutter - Aluminum	59" x 57"	56" x 54"	30.0	13.6	

HYPERMAX 50" POLY CONES

950188	50" Panel Cone Kit with Grill, 15" Long, White	17.9	8.1	
PC50SW	50" Poly Cone Kit with Grill, 15" Long, White	38.0	17.2	
PC50SB	50" Poly Cone Kit with Grill, 15" Long, Black	38.0	17.2	
936192	Hardware Bag - 36"-50" Poly & FG Cones, ZP Hardware- (Already included in with Fans)	1.5	0.7	
MH94253	Hardware Bag - 36"-50" Cone Kits only, SS Hardware - (Already included in with Fans)	1.4	0.6	

Hardware not included with cone kits. Hardware needed for cone kits comes with the fan. If ordering a cone kit without a fan, order a hardware bag separately.

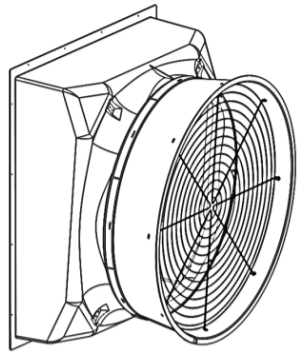

FIBERGLASS V-FAN SERIES 50" SLANT WALL DIRECT DRIVE V-FANS

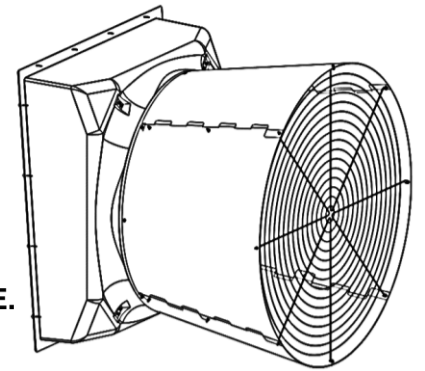

HOW TO ORDER

To order a complete 50" fiberglass V-Fan, select one(1) **FAN**, one(1) **SHUTTER**, and one(1) **CONE**.

ALUMINUM BLADE, INTERIOR MOUNT

CATALOG NUMBER	Housing	Cone Color	Blade	Mtr Mount	Motor	INPUT ELECTRIC			BESS #	BLADE SPEED	Performance Numbers tested at 230v, 60Hz with Aluminum Shutters								SHIP Weight	LIST PRICE EACH	
						Phase	Hertz	Volts			Amps	@ .00" SP	@ .05" SP	@ .10" SP	@ .15" SP	@ .20" SP	@ .25" SP	@ .30" SP			
												RPM	CFM	CFM	CFM	CFM	CFM	CFM			CFM
950230-1	White Fiberglass	White	Aluminum	Galvanized Mount	2.0 HP Fan Motor	Single Phase	50 / 60 Hz	200-240 Volts	5.9 Amps @ .30" SP	22136	692	30,000	29,000	27,800	26,800	25,600	24,300	23,000	158.0		
											57.5 Hz	15.7	14.7	13.7	12.9	12.1	11.3	10.6			
											604	26,300	24,900	23,600	22,400	21,000	19,400	16,900			71.7
											50 Hz	20.9	18.9	17.4	16.1	14.7	13.4	11.7			
											483	20,600	19,100	17,600	15,600	11,700	6,500	2,900			
											40 Hz	31.6	27.8	24.3	20.8	16.0	8.1	3.2			
											362	15,100	12,800	8,900	2,500						
											30 Hz	52.8	40.4	27.5	6.4						
302	11,700	8,800	2,000																		
25 Hz	65.7	44.1	8.5																		
950230-3	White Fiberglass	White	Aluminum	Galvanized Mount	2.0 HP Fan Motor	Three Phase	50 / 60 Hz	200-240 Volts	5.7 Amps @ .30" SP	22137	460	30,200	29,200	28,000	26,800	25,600	24,300	23,100	158.0		
											57.5 Hz	16.1	15.1	14.0	13.2	12.4	11.5	10.7			
											602	26,300	24,900	23,600	22,300	20,800	19,300	16,600			71.7
											50 Hz	21.1	19.2	17.7	16.2	14.8	13.5	11.6			
											482	20,800	19,200	17,600	15,700	10,700	6,500	2,700			
											40 Hz	32.4	28.1	24.6	21.0	14.9	8.2	3.1			
											361	15,200	12,900	8,500	2,000						
											30 Hz	54.0	41.2	26.2	5.1						
301	11,600	8,600	1,800																		
25 Hz	67.1	45.3	7.9																		
950230-34	White Fiberglass	White	Aluminum	Galvanized Mount	2.0 HP Fan Motor	Three Phase	50 / 60 Hz	420-480 Volts	3.0 Amps @ .30" SP	22138	460	30,100	29,000	27,900	26,700	25,600	24,400	23,100	158.0		
											57.5 Hz	16.3	15.3	14.2	13.4	12.5	11.7	11.0			
											602	26,200	24,900	23,600	22,300	20,900	19,200	16,400			71.7
											50 Hz	21.5	19.7	17.9	16.6	15.2	13.8	11.9			
											482	20,700	19,200	17,500	15,400	10,000	6,500	2,800			
											40 Hz	31.3	27.6	23.8	20.4	13.6	7.9	3.1			
											361	15,300	12,900	8,000	2,000						
											30 Hz	51.6	38.8	23.5	5.0						
301	11,900	8,600																			
25 Hz	62.3	41.5																			

HYPERMAX 50" SHUTTERS

CATALOG NUMBER	ITEM DESCRIPTION	OUTSIDE DIMENSIONS HEIGHT x WIDTH	SHUTTER DIMENSIONS HEIGHT X WIDTH		SHIP WGT.		LIST PRICE
			LBS	KGS	LBS	KGS	
SPM50W	PMC 50" Shutter - White PVC	59.18" x 57"	56.4" x 54.13"		27.0	12.2	
SPM50B	PMC 50" Shutter - Black PVC	59.18" x 57"	56.4" x 54.13"		26.0	11.8	
SPM50A	PMC 50" Shutter - Aluminum	59" x 57"	56" x 54"		30.0	13.6	

HYPERMAX 50" POLY CONES

950188	50" Panel Cone Kit with Grill, 15" Long, White	17.9	8.1
PC50SW	50" Poly Cone Kit with Grill, 15" Long, White	38.0	17.2
PC50SB	50" Poly Cone Kit with Grill, 15" Long, Black	38.0	17.2
936192	Hardware Bag - 36"-50" Poly & FG Cones, ZP Hardware- (Already included in with Fans)	1.5	0.7
MH94253	Hardware Bag - 36"-50" Cone Kits only, SS Hardware - (Already included in with Fans)	1.4	0.6

Hardware not included with cone kits. Hardware needed for cone kits comes with the fan. If ordering a cone kit without a fan, order a hardware bag separately.

FIBERGLASS FAN SERIES 54" HYPERMAX BELT DRIVE FANS

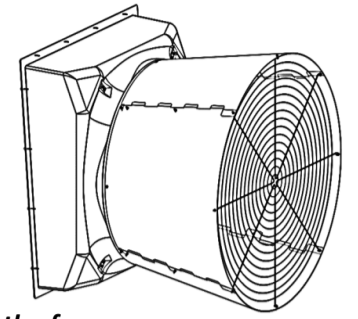

HOW TO ORDER

To order a complete 54" Hypermax fiberglass fan, select one each **FAN**, and one each **SHUTTER**.

Protection from snow or ice loads must be provided. An overhanging roof or snow guards on the roof must be provided to fully cover the fan.

VAL-CO® warranty does not apply for equipment against snow or ice damage.

If a fan is installed in a region that receives significant snowfall, Valco recommends a short cone fan (page 28-20).

HYPERMAX 54" FIBERGLASS FANS WITH LONG CONE, INTERIOR MOUNT - Single Phase

CATALOG NUMBER	Housing	Cone Color	Blade	Motor Mount	Motor / Electric				BESS #	Performance Numbers tested with Aluminum Shutters							SHIP Weight	LIST PRICE EACH								
					HP / RPM	Phase	Hertz	Volts		Amps	@ .00" SP	@ .05" SP	@ .10" SP	@ .15" SP	@ .20" SP	@ .25" SP			@ .30" SP							
					CFM	CFM	CFM	CFM		CFM	CFM	CFM	CFM	CFM	CFM	CFM	Lbs. / Kg									
954200	White FG	White	Cast Aluminum	Galvanized	1.5 / 1725	Single Phase	60 Hz	230 Volts	6.10A @ 230V @ .30" SP	15647	30,500	28,900	27,000	24,600	21,900	18,300	9,300	271 / 123								
954200-SC	White FG										SS	1.5 / 1725	Single Phase	60 Hz	230 Volts	7.03A @ 230V @ .30" SP	15648	32,100	30,700	28,800	26,700	24,300	21,300	16,800	271 / 123	
954200-BW	White/Black										Galvanized	1.5 / 1725	Single Phase	60 Hz	230 Volts	7.03A @ 230V @ .30" SP	15648	24.9	22.6	20.4	18.1	15.9	13.6	10.5	271 / 123	
954210	White FG	White	Cast Aluminum	Galvanized	1.5 / 1725	Single Phase	60 Hz	230 Volts	6.04A @ 230V @ .30" SP	15646	29,800	28,500	27,100	25,000	22,500	19,500	15,200	265 / 120								
954210-SC	White FG										SS	1.5 / 1725	Single Phase	60 Hz	230 Volts	7.23A @ 230V @ .30" SP	15649		32,000	30,600	29,100	27,400	25,200	22,700	19,700	265 / 120
954210-BW	White/Black										Galvanized	1.5 / 1725	Single Phase	60 Hz	230 Volts	7.23A @ 230V @ .30" SP	15649	23.2	21.4	19.6	17.8	15.9	14.0	12.0		

BW - Sable fan has a White exterior housing and a black interior housing.

SC - Stainless Steel Motor Mount and Hardware

54" SHUTTERS

CATALOG NUMBER	ITEM DESCRIPTION	OUTSIDE DIMENSIONS HEIGHT x WIDTH	SHUTTER DIMENSIONS HEIGHT X WIDTH	SHIP WEIGHT		LIST PRICE
				LBS	KGS	
SPM54W	54" Shutter - White PVC	61.5" x 61.5"	59" x 59"	34.0	15.4	
SPM54B	54" Shutter - Black PVC	61.5" x 61.5"	59" x 59"	30.0	13.6	
SPM54A	54" Shutter - Aluminum	61.35" x 61.35"	58.25" x 58.25"	38.0	17.2	

54" FIBERGLASS FAN OPTIONS

954226	Kit, 54" Cone Reinforcement for Snow Load	20.0	9.1	
--------	---	------	-----	--

FIBERGLASS FAN SERIES 54" HYPERMAX BELT DRIVE FANS

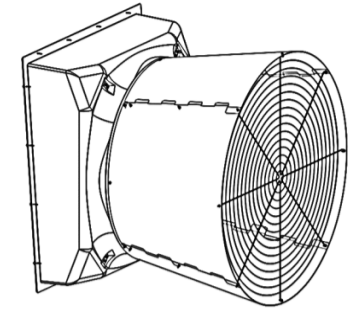

HOW TO ORDER

To order a complete 54" Hypermax fiberglass fan, select one each **FAN**, and one each **SHUTTER**.

Protection from snow or ice loads must be provided. An overhanging roof or snow guards on the roof must be provided to fully cover the fan.

VAL-CO® warranty does not apply for equipment against snow or ice damage.

If a fan is installed in a region that receives significant snowfall, Valco recommends a short cone fan (page 28-20).

HYPERMAX 54" FIBERGLASS FANS WITH LONG CONE, INTERIOR MOUNT - 3 Phase

CATALOG NUMBER	Housing	Cone Color	Blade	Motor Mount	Motor / Electric				BESS #	Performance Numbers tested with Aluminum Shutters							SHIP Weight	LIST PRICE EACH	
					HP / RPM	Phase	Hertz	Volts		Amps	@ .00" SP	@ .05" SP	@ .10" SP	@ .15" SP	@ .20" SP	@ .25" SP			@ .30" SP
					CFM	CFM/W	CFM	CFM/W		CFM	CFM/W	CFM	CFM/W	CFM	CFM/W	CFM	CFM/W		Lbs. / Kg
954245	White FG	White	Cast Aluminum	Galv.	1.5 / 1725	Three	60 Hz	208-230 / 460 Volts	4.93A @ 230V @ .30" SP	15655	32,500	31,100	29,400	27,400	24,900	22,100	18,800	258 / 117	
954245-SC	White FG	White	Stainless Steel	SS							24.6	22.5	20.4	18.3	16.1	13.9	11.6	258 / 117	
954245-BW	White/Black	White	Cast Aluminum	Galvanized							24.6	22.5	20.4	18.3	16.1	13.9	11.6	258 / 117	
954240	White	White	Galvanized	Galvanized	1.5 / 1725	Three	60 Hz	208-230/460	4.89A @ 230V @ .30" SP	15654	32,000	30,700	29,200	27,400	25,200	22,700	19,700	252 / 114	
954240	White	White	Galvanized	Galvanized							24.4	22.5	20.5	18.6	16.5	14.5	12.3	252 / 114	
954280	White	White	Cast Aluminum	Galv.	2.0 / 1725	Three	60 Hz	208-230 / 460 Volts	6.26A @ 230V @ .30" SP	22389	36,500	35,000	33,200	31,400	29,500	27,400	24,700	268 / 122	
954280-SC	White	White	Stainless Steel	SS							19.6	18.1	16.5	15.1	13.8	12.6	11.1	268 / 122	
954280-BW	White/Black	White	Cast Aluminum	Galvanized							19.6	18.1	16.5	15.1	13.8	12.6	11.1	268 / 122	
954285	White	White	Galvanized	Galvanized	2.0 / 1725	Three	60 Hz	208-230/460	5.61A @ 230V @ .30" SP	22387	34,100	32,700	31,300	29,500	27,900	25,700	23,300	262 / 119	
954285	White	White	Galvanized	Galvanized							21.0	19.4	17.9	16.4	15.0	13.4	11.9	262 / 119	
954255	White FG	White	Aluminum	Galv.	1.5 / 1425	Three	50 Hz	190 / 380	2.50A @ 380V @ .25" SP	17073	31,300	29,700	27,500	25,300	22,800	19,300	14,500	258 / 117	
954255-SC	White FG	White	Aluminum	Stainless Steel							26.6	24.0	21.4	18.8	16.3	13.6	10.3	258 / 117	
954295	White	White	Galvanized	Galvanized	1.5 / 1425	Three	50 Hz	190 / 380	3.03A @ 380V @ .30" SP	17074	32,600	31,100	29,700	27,700	25,800	23,200	20,400	252 / 114	
954295	White	White	Galvanized	Galvanized							21.4	19.7	18.1	16.4	14.9	13.1	11.4	252 / 114	

BW - Sable fan has a White exterior housing and a black interior housing.

SC - Stainless Steel Motor Mount and Hardware

54" SHUTTERS & CONE REINFORCEMENT

CATALOG NUMBER	ITEM DESCRIPTION	OUTSIDE DIMENSIONS HEIGHT x WIDTH	SHUTTER DIMENSIONS HEIGHT X WIDTH	SHIP WEIGHT		LIST PRICE
				LBS	KGS	
SPM54W	54" Shutter - White PVC	61.5" x 61.5"	59" x 59"	34.0	15.4	
SPM54B	54" Shutter - Black PVC	61.5" x 61.5"	59" x 59"	30.0	13.6	
SPM54A	54" Shutter - Aluminum	61.35" x 61.35"	58.25" x 58.25"	38.0	17.2	
954226	Kit, 54" Cone Reinforcement for Snow Load			20.0	9.1	

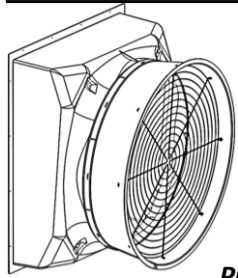

FIBERGLASS FAN SERIES

54" HYPERMAX BELT DRIVE FANS

HOW TO ORDER

To order a complete 54" Hypermax fiberglass fan, select one each **FAN**, and one each **SHUTTER**.
Protection from snow/ice loads must be provided. Overhanging roof or snow guards on the roof must be provided to fully cover the fan.

VAL-CO® warranty does not apply for equipment against snow or ice damage.

If a fan is installed in a region that receives significant snowfall, Valco recommends a short cone fan (page 28-20).

HYPERMAX 54" FIBERGLASS FANS WITH SHORT CONE, INTERIOR MOUNT

CATALOG NUMBER	FG Housing	Cone Color	Blade	Motor Mount	Motor / Electric				BESS #	Performance Numbers tested with Aluminum Shutters							SHIP Weight Lbs. / Kg	LIST PRICE EACH	
					HP / RPM	Phase	Hertz	Volts		Amps	@ .00" SP	@ .05" SP	@ .10" SP	@ .15" SP	@ .20" SP	@ .25" SP			@ .30" SP
											CFM	CFM	CFM	CFM	CFM	CFM			CFM
954800	White FG	White	Aluminum Blade	Galv.	1.5 / 1725	Single Phase	60 Hz	230 Volts	6.28 Amps @ 230v @ .30" SP	19465	29,200	27,500	25,600	23,500	21,100	17,500	10,200	238 / 108	
954800-SC	White	White	SS	241 / 109															
954800-BW	White/Black	Black	Aluminum Blade	Galv.	1.5 / 1725	Single Phase	60 Hz	230 Volts	6.28 Amps @ 230v @ .30" SP	19465	23.9	21.9	19.6	17.7	15.5	12.6	7.5	238 / 108	
954810	White FG	White	Aluminum Blade	Galv.	1.5 / 1725	Single Phase	60 Hz	230 Volts	6.22 Amps @ 230v @ .30" SP	19464	29,600	28,000	26,000	24,100	21,900	18,500	14,400	238 / 108	
954810-SC	White	White	SS	241 / 109															
954810-BW	White/Black	Black	Aluminum Blade	Galv.	1.5 / 1725	Single Phase	60 Hz	230 Volts	6.22 Amps @ 230v @ .30" SP	19464	24.0	21.9	19.6	17.8	15.8	13.2	10.2	238 / 108	
954815	White FG	White	Galvanized	Galvanized	1.5 / 1725	Single	60 Hz	230	6.45 Amps @ 230v @ .30" SP	19467	29,500	28,100	26,500	24,600	22,800	20,300	16,900	231 / 105	
											22.3	20.8	19.1	17.5	15.8	14.0	11.5		
954845	White FG	White	Aluminum	Galv.	1.5 / 1725	Three Phase	60 Hz	208-230/460	4.92 Amps @ 230v @ .30" SP	19472	30,800	29,200	27,400	25,600	23,600	21,400	17,700	224 / 102	
954845-SC	White	White	SS	226 / 103															
954880	White	White	Aluminum	Galvanized	2.0 / 1725	Three Phase	60 Hz	208-230 / 460	6.28 Amps @ 230v @ .30" SP	22391	34,000	32,400	30,900	29,300	27,500	25,800	23,600	239 / 108	
954880-BW	White/Black	Black									239 / 108								
954880-SC	White	White									SS	241 / 109							
954840	White FG	White	Galvanized	Galvanized	1.5 / 1725	Three	60 Hz	208-230/460	4.56 Amps @ 230v @ .30" SP	19473	29,100	27,600	26,000	24,300	22,500	20,100	17,100	217 / 98	
											24.0	21.6	19.7	17.8	16.1	14.1	11.6		

BW - Sable fan has a White exterior housing and a black interior housing.

SC - Stainless Steel Motor Mount and Hardware

54" SHUTTERS

CATALOG NUMBER	ITEM DESCRIPTION	OUTSIDE DIMENSIONS HEIGHT x WIDTH	SHUTTER DIMENSIONS HEIGHT X WIDTH	SHIP WGHT.		LIST PRICE
				LBS	KGS	
SPM54W	54" Shutter - White PVC	61.5" x 61.5"	59" x 59"	34.0	15.4	
SPM54B	54" Shutter - Black PVC	61.5" x 61.5"	59" x 59"	30.0	13.6	
SPM54A	54" Shutter - Aluminum	61.35" x 61.35"	58.25" x 58.25"	38.0	17.2	

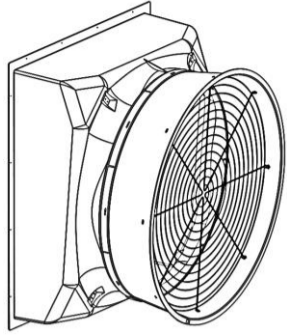

FIBERGLASS V-FAN SERIES

54" SLANT WALL DIRECT DRIVE V-FANS

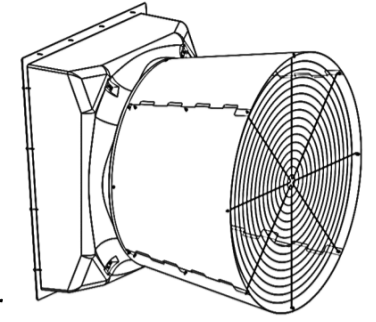

HOW TO ORDER

To order a complete 54" fiberglass fan, select one each **FAN**, and one each **SHUTTER**.

Protection from snow or ice loads must be provided. An overhanging roof or snow guards on the roof must be provided to fully cover

VAL-CO® warranty does not apply for equipment against snow or ice damage.

If a fan is installed in a region that receives significant snowfall, Valco recommends a short cone fan (page 28-20).

ALUMINUM BLADE with SHORT CONE, INTERIOR MOUNT

CATALOG NUMBER	Housing	Cone Color	Blade	Mtr Mount	Motor	INPUT ELECTRIC			BESS #	BLADE SPEED	Performance Numbers tested at 230v, 60Hz with Aluminum Shutters							SHIP Weight	LIST PRICE EACH									
						Phase	Hertz	Volts			Amps	@ .00" SP	@ .05" SP	@ .10" SP	@ .15" SP	@ .20" SP	@ .25" SP			@ .30" SP								
												RPM	CFM	CFM	CFM	CFM	CFM			CFM	CFM	CFM	CFM					
954830-1	White Fiberglass	White	Aluminum Blade	Galv.	2.0 HP Fan Motor	Single Phase	50 / 60 Hz	200-240 Volts	15.3 Amps @ .30" SP	19474	620	35,000	33,600	32,200	30,600	29,100	27,300	25,300	241.0									
954830-SC-1	White Fiberglass	White	Aluminum Blade	Stainless							51.6 Hz	18.4	17.1	15.9	14.7	13.6	12.4	11.3										
954830-BW-1	Black Int.*	Black	Aluminum Blade	Galv.							2.0 HP Fan Motor	Single Phase	50 / 60 Hz	200-240 Volts	15.3 Amps @ .30" SP	19474	603	34,000			32,400	31,000	29,400	27,800	26,000	23,800	109.4	
																	50 Hz	19.8			18.2	16.8	15.6	14.3	13.1	11.8		
																	482	27,100			25,300	23,300	21,000	17,900	10,300	6,000		
954830-3	White Fiberglass	White	Aluminum Blade	Galv.							2.0 HP Fan Motor	Three Phase	50 / 60 Hz	200-240 Volts	7.8 Amps @ .30" SP	19477	620	34,400			33,100	31,600	30,200	28,600	26,800	24,900	241.0	
					51.6 Hz	18.9	17.5	16.2	15.1	13.9							12.7	11.6										
					600	33,400	32,000	30,400	29,000	27,300							25,300	23,400										
954830-SC-3	White Fiberglass	White	Aluminum Blade	Stainless	2.0 HP Fan Motor	Three Phase	50 / 60 Hz	200-240 Volts	7.8 Amps @ .30" SP	19477	480	26,700	24,900	23,000	20,600	18,000	12,700	109.4										
954830-BW-SC-3	Black Int.*	Black	Aluminum Blade	Galv.							40 Hz	31.5	27.8	25.1	21.1	18.1	12.6											
											360	19,400	16,900	13,200	4,800													
											30Hz	58.6	50.6	32.0	10.3													
954830-BW-3	Black Int.*	Black	Aluminum Blade	Galv.	2.0 HP Fan Motor	Three Phase	50 / 60 Hz	200-240 Volts	7.8 Amps @ .30" SP	19477	300	15,300	12,300					109.4										
954830-BW-3	Black Int.*	Black	Aluminum Blade	Galv.							25 Hz	66.9	50.3															
											301	15,700	12,600															

ALUMINUM BLADE with LONG CONE, INTERIOR MOUNT

954230-1	White Fiberglass	White	Aluminum Blade	Galv.	2.0 HP Fan Motor	Single Phase	50 / 60 Hz	200-240 Volts	14.9 Amps @ .30" SP	19475	625	37,700	36,200	34,600	33,000	31,100	29,100	26,800	257.0								
954230-SC-1	White Fiberglass	White	Aluminum Blade	Stainless							52.1 Hz	21.4	19.3	17.7	16.2	14.8	13.3	11.9									
											602	36,200	34,700	33,100	31,300	29,300	27,100	24,700									
954230-BW-1	Black Int.*	Black	Aluminum Blade	Galv.							2.0 HP Fan Motor	Single Phase	50 / 60 Hz	200-240 Volts	14.9 Amps @ .30" SP	19475	482	29,000			27,000	24,700	22,200	19,200	9,600	116.6	
																	40 Hz	35.3			30.6	26.2	22.9	18.9	9.3		
																	361	21,100			18,300	14,400	5,100				
954230-3	White Fiberglass	White	Aluminum Blade	Galv.	2.0 HP Fan Motor	Three Phase	50 / 60 Hz	200-240 Volts	7.8 Amps @ .30" SP	19476	625	37,300	35,800	34,400	32,700	30,800	28,800	26,600	257.0								
											52.1 Hz	21.9	20.0	18.3	16.7	15.0	13.7	12.4									
954230-SC-3	White Fiberglass	White	Aluminum Blade	Stainless	2.0 HP Fan Motor	Three Phase	50 / 60 Hz	200-240 Volts	7.8 Amps @ .30" SP	19476	599	35,800	34,400	32,900	31,100	29,000	26,900	24,500	116.6								
954230-BW-3	Black Int.*	Black	Aluminum Blade	Galv.							480	28,900	26,800	24,600	22,100	18,100	13,300										
											40 Hz	38.9	31.3	27.5	24.4	18.6	13.3										
											359	20,700	18,200	14,100	5,500												
954230-BW-3	Black Int.*	Black	Aluminum Blade	Galv.	2.0 HP Fan Motor	Three Phase	50 / 60 Hz	200-240 Volts	7.8 Amps @ .30" SP	19476	30Hz	60.6	49.1	34.3	12.2				116.6								
											300	16,200	13,100														
954230-BW-3	Black Int.*	Black	Aluminum Blade	Galv.	2.0 HP Fan Motor	Three Phase	50 / 60 Hz	200-240 Volts	7.8 Amps @ .30" SP	19476	25 Hz	77.2	55.4					116.6									
											300	16,200	13,100														

BW - Sable fan has a White exterior housing and a black interior housing.

SC - Stainless Steel Motor Mount and Hardware

54" SHUTTERS & CONE REINFORCEMENT

CATALOG NUMBER	ITEM DESCRIPTION	OUTSIDE DIMENSIONS HEIGHT x WIDTH	SHUTTER DIMENSIONS HEIGHT x WIDTH	SHIP WEIGHT		LIST PRICE
				LBS	KGS	
SPM54W	54" Shutter - White PVC	61.5" x 61.5"	59" x 59"	34.0	15.4	
SPM54B	54" Shutter - Black PVC	61.5" x 61.5"	59" x 59"	30.0	13.6	
SPM54A	54" Shutter - Aluminum	61.35" x 61.35"	58.25" x 58.25"	38.0	17.2	
954226	Kit, 54" Cone Reinforcement for Snow Load			20.0	9.1	

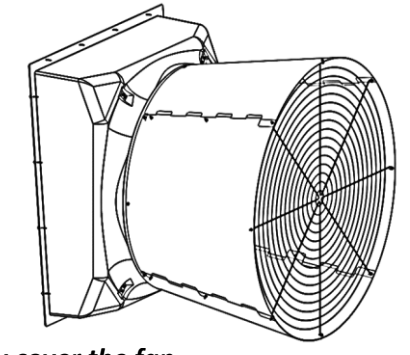
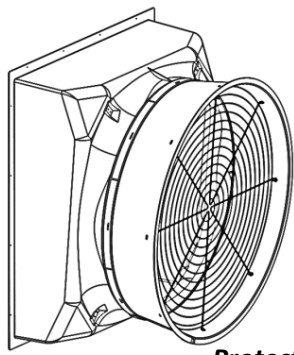

FIBERGLASS V-FAN SERIES

54" SLANT WALL DIRECT DRIVE V-FANS

HOW TO ORDER

To order a complete 54" Hypermax fiberglass fan, select one each **FAN**, and one each **SHUTTER**.

Protection from snow or ice loads must be provided. An overhanging roof or snow guards on the roof must be provided to fully cover the fan.

VAL-CO® warranty does not apply for equipment against snow or ice damage.

If a fan is installed in a region that receives significant snowfall, Valco recommends a short cone fan (page 28-20).

GALVANIZED BLADE with SHORT CONE, INTERIOR MOUNT

CATALOG NUMBER	Housing	Cone Color	Blade	Mtr Mount	Motor	INPUT ELECTRIC				BESS #	BLADE SPEED	Performance Numbers tested at 230v, 60Hz with Aluminum Shutters							SHIP Weight	LIST PRICE EACH
						Phase	Hertz	Volts	Amps			@ .00" SP	@ .05" SP	@ .10" SP	@ .15" SP	@ .20" SP	@ .25" SP	@ .30" SP		
												RPM	CFM	CFM	CFM	CFM	CFM	CFM		
954835-1	White Fiberglass	White	Galvanized Blade	Galvanized Motor Mount	2.0 HP Fan Motor	Single Phase	50 / 60 Hz	200-240 Volts	12.9 Amps @ .30" SP	19486	603	33,200	32,000	30,700	29,300	27,900	26,200	24,400	234.0	
											50 Hz	19.7	18.0	17.0	15.8	14.8	13.7	12.4		
											482	27,000	25,400	23,500	21,600	19,200	16,000	7,500	106.2	
											40 Hz	29.9	26.8	24.0	21.5	18.7	15.3	7.2		
											361	19,800	17,600	14,500	6,700					
											30 Hz	49.9	41.7	32.7	14.6					
301	15,900	12,700																		
25 Hz	65.0	49.6																		
954835-3	White Fiberglass	White	Galvanized Blade	Galvanized Motor Mount	2.0 HP Fan Motor	Three Phase	50 / 60 Hz	200-240 Volts	6.8 Amps @ .30" SP	19478	600	33,000	31,900	30,500	29,200	27,500	26,100	24,200	234.0	
											50 Hz	19.9	18.6	17.3	16.2	14.9	13.8	12.6		
											479	27,000	25,100	23,300	21,300	18,800	14,700	6,900	106.2	
											40 Hz	30.8	27.1	24.4	21.9	18.9	14.6	6.8		
											359	19,900	17,500	14,500	6,400					
											30 Hz	52.0	43.2	33.9	14.5					
300	16,100	13,200																		
25 Hz	67.2	52.2																		

GALVANIZED BLADE with LONG CONE, INTERIOR MOUNT

954235-1	White Fiberglass	White	Galvanized Blade	Galvanized Motor Mount	2.0 HP Fan Motor	Single Phase	50 / 60 Hz	200-240 Volts	12.8 Amps @ .30" SP	19482	602	34,900	33,700	32,400	31,100	29,500	27,500	25,500	251.0
											50 Hz	22	20	18.7	17.2	15.9	14.5	13.1	
											482	28,500	26,800	25,100	22,700	20,200	16,000	7,600	113.9
											40 Hz	33.6	29.5	26.5	23.0	19.9	15.6	7.4	
											361	21,000	18,600	15,300	6,900				
											30 Hz	56.5	45.3	34.9	14.9				
301	17,000	13,800																	
25 Hz	72.5	53.9																	
954235-3	White Fiberglass	White	Galvanized Blade	Galvanized Motor Mount	2.0 HP Fan Motor	Three Phase	50 / 60 Hz	200-240 Volts	6.8 Amps @ .30" SP	19481	600	34,800	33,500	32,200	30,800	29,200	27,300	25,100	251.0
											50 Hz	22.6	20.5	19.0	17.6	16.1	14.7	13.2	
											480	28,300	26,600	24,900	22,700	20,000	16,100	7,500	113.9
											40 Hz	33.9	29.8	26.7	23.4	20.1	15.9	7.4	
											360	21,000	18,700	115,100	7,600				
											30 Hz	57.3	46.5	35.3	16.9				
300	16,900	13,800																	
25 Hz	75.0	55.0																	

54" SHUTTERS & CONE REINFORCEMENT

CATALOG NUMBER	ITEM DESCRIPTION	OUTSIDE DIMENSIONS HEIGHT x WIDTH	SHUTTER DIMENSIONS HEIGHT X WIDTH	SHIP WEIGHT		LIST PRICE
				LBS.	KGS	
SPM54W	54" Shutter - White PVC	61.5" x 61.5"	59" x 59"	34.0	15.4	
SPM54B	54" Shutter - Black PVC	61.5" x 61.5"	59" x 59"	30.0	13.6	
SPM54A	54" Shutter - Aluminum	61.35" x 61.35"	58.25" x 58.25"	38.0	17.2	
954226	Kit, 54" Cone Reinforcement for Snow Load			20.0	9.1	

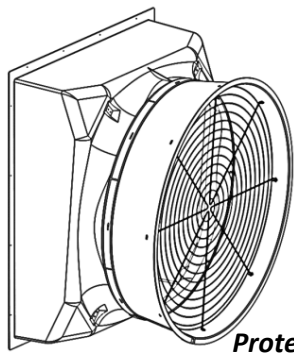

FIBERGLASS V-FAN SERIES

54" SLANT WALL DIRECT DRIVE V-FANS

3 PHASE 380-420 Volt INPUT

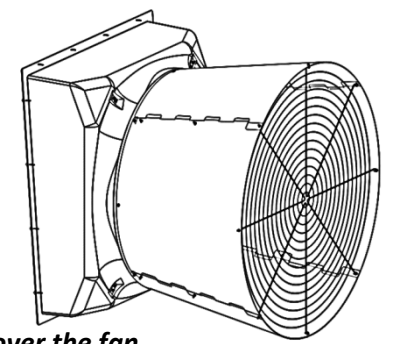

HOW TO ORDER

To order a complete 54" Hypermax fiberglass fan, select one each **FAN**, and one each **SHUTTER**.

Protection from snow or ice loads must be provided. An overhanging roof or snow guards on the roof must be provided to fully cover the fan.

VAL-CO® warranty does not apply for equipment against snow or ice damage.

If a fan is installed in a region that receives significant snowfall, Valco recommends a short cone fan (page 28-20).

SHORT CONE, INTERIOR MOUNT

CATALOG NUMBER	Housing	Cone Color	Blade	Mtr Mount	Motor	INPUT ELECTRIC			BESS #	BLADE SPEED RPM Hz	Performance Numbers tested at 380v, 50Hz with Aluminum Shutters							SHIP Weight LBS. KGS	LIST PRICE EACH			
						Phase	Hertz	Volts			Amps	@ .00" SP	@ .05" SP	@ .10" SP	@ .15" SP	@ .20" SP	@ .25" SP			@ .30" SP		
																					CFM	CFM/W
954830-33	White Fiberglass	White	Aluminum Blade	Galvanized Motor Mount	2.0 HP Fan Motor	Three Phase	50 / 60 Hz	380-420 Volts	2.95 Amps @ .30" SP	20478	632	35,100	33,700	32,500	31,000	29,500	27,900	26,100	240.0			
											52.5 Hz	18.3	16.9	15.8	14.8	13.7	12.7	11.7				
											603	33,500	32,000	30,700	29,100	27,400	25,700	22,800			108.9	
											50 Hz	20.0	18.5	17.3	15.9	14.6	13.5	11.8				
											482	26,800	25,000	23,100	20,900	17,700	14,100					
											40 Hz	31.3	27.6	24.6	21.6	17.9	13.9					
362	19,100	17,100	14,000	5,000																		
30 Hz	52.7	43.1	33.5	10.4																		
301	15,600	12,600	3,500																			
25 Hz	68.6	51.5	11.8																			
954835-33	White Fiberglass	White	Galvanized Blade	Galvanized Motor Mount	2.0 HP Fan Motor	Three Phase	50 / 60 Hz	380-420 Volts	3.06 Amps @ .30" SP	20477	602	33,000	31,900	30,600	29,300	28,000	26,400	24,700	233.0			
											50 Hz	20.1	18.8	17.5	16.4	15.4	14.1	13				
											482	26,900	25,400	23,800	21,800	19,200	16,400	8,200			105.7	
											40 Hz	30.2	27.4	24.9	22.2	19.4	16.4	8.3				
											361	20,100	17,900	15,000	8,900							
											30 Hz	52.2	43.7	234.8	20.1							
301	16,200	13,300	5,400																			
25 Hz	66.4	52.1	19.6																			

LONG CONE, INTERIOR MOUNT

954230-33	White Fiberglass	White	Aluminum Blade	Galvanized	2.0 HP Fan Motor	Three Phase	50 / 60 Hz	380-420 Volts	3.57 Amps @ .30" SP	20474	632	37,400	36,000	34,600	33,000	31,300	29,500	27,400	259.0			
											52.5 Hz	20.9	19.4	17.8	16.3	14.9	13.7	12.4				
											603	35,600	34,200	32,700	31,100	29,100	24,100	24,700				
954230-SC-33	White Fiberglass	White	Aluminum Blade	SS	2.0 HP Fan Motor	Three Phase	50 / 60 Hz	380-420 Volts	3.57 Amps @ .30" SP	20474	482	28,800	26,900	24,700	22,000	19,100	15,300		117.5			
											40 Hz	36.0	31.2	26.9	22.8	19.5	15.0					
											361	20,800	18,200	14,600	6,500							
954235-33	White Fiberglass	White	Galvanized Blade	Galvanized Motor Mount	2.0 HP Fan Motor	Three Phase	50 / 60 Hz	380-420 Volts	3.04 Amps @ .30" SP	20475	602	34,800	33,500	32,200	31,000	29,400	27,800	25,700	252.0			
											50 Hz	22.6	20.8	19.2	17.8	16.4	15.2	13.7				
											482	28,500	26,900	25,000	23,100	20,100	16,800	16,900			114.4	
											40 Hz	34.3	30.3	26.6	23.8	20.6	16.9	9.7				
											361	21,000	18,800	15,700	8,200							
											30 Hz	57.8	46.9	36.8	18.5							
301	16,800	14,200	6,100																			
25 Hz	72.0	57.1	18.3																			

54" SHUTTERS & CONE REINFORCEMENT

CATALOG NUMBER	ITEM DESCRIPTION	OUTSIDE DIMENSIONS HEIGHT x WIDTH	SHUTTER DIMENSIONS HEIGHT X WIDTH	SHIP WEIGHT		LIST PRICE
				LBS.	KGS	
SPM54W	54" Shutter - White PVC	61.5" x 61.5"	59" x 59"	34.0	15.4	
SPM54B	54" Shutter - Black PVC	61.5" x 61.5"	59" x 59"	30.0	13.6	
SPM54A	54" Shutter - Aluminum	61.35" x 61.35"	58.25" x 58.25"	38.0	17.2	
954226	Kit, 54" Cone Reinforcement for Snow Load			20.0	9.1	

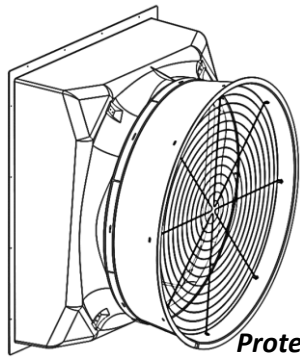

FIBERGLASS V-FAN SERIES

54" SLANT WALL DIRECT DRIVE V-FANS

3 PHASE 420-480 Volt INPUT

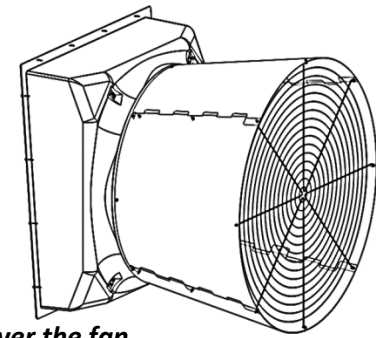

HOW TO ORDER

To order a complete 54" Hypermax fiberglass fan, select one each **FAN**, and one each **SHUTTER**.

Protection from snow or ice loads must be provided. An overhanging roof or snow guards on the roof must be provided to fully cover the fan.

VAL-CO® warranty does not apply for equipment against snow or ice damage.

If a fan is installed in a region that receives significant snowfall, Valco recommends a short cone fan (page 28-20).

SHORT CONE, INTERIOR MOUNT

CATALOG NUMBER	Housing	Cone Color	Blade	Mtr Mount	Motor	INPUT ELECTRIC			BESS #	BLADE SPEED RPM Hz	Performance Numbers tested at 460v, 60Hz with Aluminum Shutters							SHIP Weight LBS. KGS	LIST PRICE EACH	
						Phase	Hertz	Volts			Amps									
												@ .00" SP	@ .05" SP	@ .10" SP	@ .15" SP	@ .20" SP	@ .25" SP			@ .30" SP
954830-34	White FG	White	Aluminum Blade	Galvanized Motor Mount	2.0 HP Fan Motor	Three Phase	50 / 60 Hz	420-480 Volts	2.57 Amps @ .30" SP	20486	632	35,200	33,800	32,400	30,900	29,500	27,900	26,200	240.0	
											52.5 Hz	18.7	17.3	16.0	14.9	13.8	12.8	11.8		
											600	33,400	32,200	30,600	29,200	27,500	25,800	23,700		
											50 Hz	20.3	18.9	17.4	16.1	14.9	13.6	12.3		
954830-BW-34	Black / White	Black	Aluminum Blade	Galvanized Motor Mount	2.0 HP Fan Motor	Three Phase	50 / 60 Hz	420-480 Volts	2.57 Amps @ .30" SP	20486	479	26,900	25,200	23,200	20,800	18,200	10,500	108.9		
											40 Hz	31.5	27.9	24.8	21.5	18.3	10.6			
											359	19,300	17,000	13,800	5,000					
											30 Hz	52.4	42.2	32.6	10.4					
954835-34	White FG	White	Galvanized Blade	Galvanized Motor Mount	2.0 HP Fan Motor	Three Phase	50 / 60 Hz	420-480 Volts	2.52 Amps @ .30" SP	20485	600	32,900	31,900	30,500	29,300	27,900	26,300	24,700	233.0	
											50 Hz	20.2	18.9	17.5	16.5	15.4	14.2	13.1		
											480	26,900	25,300	23,500	21,700	19,200	16,200	9,100		
											40 Hz	30.6	27.5	24.8	22.5	19.3	16.1	9.2		
954835-BW-34	Black / White	Black	Galvanized Blade	Galvanized Motor Mount	2.0 HP Fan Motor	Three Phase	50 / 60 Hz	420-480 Volts	2.52 Amps @ .30" SP	20485	360	20,100	17,800	14,900	8,600				105.7	
											30 Hz	52.3	43.0	34.9	19.6					
											300	16,200	13,400	3,800						
											25 Hz	66.5	51.1	13.4						

LONG CONE, INTERIOR MOUNT

954230-34	White FG	White	Aluminum Blade	Galv.	2.0 HP Fan Motor	Three Phase	50 / 60 Hz	420-480 Volts	2.93 Amps @ .30" SP	20481	632	37,400	36,100	34,500	33,000	31,200	29,400	27,400	259.0												
											52.5 Hz	21.2	19.5	17.9	16.5	15.1	13.8	12.6													
											600	35,700	34,200	2,500	30,900	29,200	26,900	24,800													
											50 Hz	23.3	21.3	19.2	17.7	16.1	14.5	13.1													
954230-SC-34	White	White	Aluminum Blade	SS	2.0 HP Fan Motor	Three Phase	50 / 60 Hz	420-480 Volts	2.93 Amps @ .30" SP	20481	479	28,600	26,600	24,400	22,100	19,100	14,600		117.5												
											40 Hz	36.0	31.5	16.8	23.3	19.6	14.6														
											359	20,600	17,900	14,600	8,400																
											30 Hz	59.5	46.7	35.3	18.2																
954230-BW-34	Black/White	Black	Aluminum Blade	Galv.	2.0 HP Fan Motor	Three Phase	50 / 60 Hz	420-480 Volts	2.93 Amps @ .30" SP	20481	300	17,000	13,800	3,900					117.5												
											25 Hz	79.3	56.4	13.4																	
											600	34,800	33,500	32,200	30,900	29,300	27,600	25,600													
											50 Hz	22.8	20.9	19.3	17.8	16.5	15.1	13.7													
954235-34	White Fiberglass	White	Galvanized Blade	Galvanized Motor Mount	2.0 HP Fan Motor	Three Phase	50 / 60 Hz	420-480 Volts	2.49 Amps @ .30" SP	20482	480	28,300	26,800	25,100	22,700	20,300	16,800	9,400	252.0												
											40 Hz	33.9	30.6	27.0	23.6	20.4	16.8	9.5													
											360	21,500	19,200	15,600	9,000																
											954235-34	White Fiberglass	White	Galvanized Blade	Galvanized Motor Mount	2.0 HP Fan Motor	Three Phase	50 / 60 Hz	420-480 Volts	2.49 Amps @ .30" SP	20482	30 Hz	57.8	45.7	36.3	20.3				114.4	
																						300	16,800	14,200	5,300						
																						25 Hz	69.9	56.0	19.2						

54" SHUTTERS & CONE REINFORCEMENT

CATALOG NUMBER	ITEM DESCRIPTION	OUTSIDE DIMENSIONS HEIGHT x WIDTH	SHUTTER DIMENSIONS HEIGHT X WIDTH	SHIP WEIGHT		LIST PRICE
				LBS.	KGS	
SPM54W	54" Shutter - White PVC	61.5" x 61.5"	59" x 59"	34.0	15.4	
SPM54B	54" Shutter - Black PVC	61.5" x 61.5"	59" x 59"	30.0	13.6	
SPM54A	54" Shutter - Aluminum	61.35" x 61.35"	58.25" x 58.25"	38.0	17.2	
954226	Kit, 54" Cone Reinforcement for Snow Load			20.0	9.1	

FIBERGLASS FAN SERIES

54" HYPERMAX BELT DRIVE FANS - EXTERIOR MOUNT

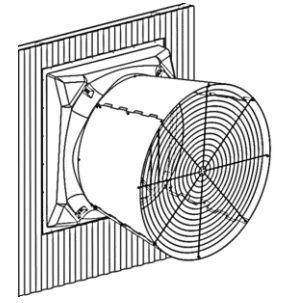

HOW TO ORDER

To order a complete 54" Hypermax fiberglass fan, select one each **FAN**, and one each **SHUTTER** as needed.

LONG CONE, EXTERIOR MOUNT

CATALOG NUMBER	Housing	Cone Color	Blade	Motor Mount	Motor / Electric				BESS #	Performance Numbers tested with Aluminum Shutters							SHIP Weight Lbs. / Kg	LIST PRICE EACH	
					HP/RPM	Phase	Hertz	Volts		Amps	@ .00" SP	@ .05" SP	@ .10" SP	@ .15" SP	@ .20" SP	@ .25" SP			@ .30" SP
											CFM	CFM	CFM	CFM	CFM	CFM			CFM
954201	White FG	White	Aluminum	Galv.	1.5 / 1725	Single	60 Hz	230 Volt	6.06A @ 230V @ .30 SP	15665	30,000	28,700	26,700	24,400	21,500	16,800	8,800	266 / 121	
954201-SC	White FG	White	Aluminum	SS	1.5 / 1725	Single	60 Hz	230 Volt	6.06A @ 230V @ .30 SP	15665	26.7	24.5	21.8	19.3	16.5	12.6	6.3	266 / 121	
954211	White FG	White	Aluminum	Galv.	1.5 / 1725	Single	60 Hz	230 Volt	6.98A @ 230V @ .30 SP	15666	31,600	30,200	28,600	26,600	24,000	21,000	15,800	260 / 118	
954211-SC	White FG	White	Aluminum	SS	1.5 / 1725	Single	60 Hz	230 Volt	6.98A @ 230V @ .30 SP	15666	24.4	22.2	20.3	18.1	15.9	13.6	10.0	260 / 118	
954206	White FG	White	Galvanized	Galvanized	1.5 / 1725	Single	60 Hz	230	5.91A @ 230V @ .30 SP	15664	29,400	28,000	26,600	24,700	22,400	19,000	14,200	260 / 118	
954206	White FG	White	Galvanized	Galvanized	1.5 / 1725	Single	60 Hz	230	5.91A @ 230V @ .30 SP	15664	26.1	23.9	21.8	19.8	17.3	14.3	10.5	260 / 118	
954216	White FG	White	Galvanized	Galvanized	1.5 / 1725	Single	60 Hz	230	7.13A @ 230V @ .30 SP	15667	31,600	30,300	28,900	27,200	25,100	22,400	18,900	223 / 101	
954216	White FG	White	Galvanized	Galvanized	1.5 / 1725	Single	60 Hz	230	7.13A @ 230V @ .30 SP	15667	23.0	21.2	19.5	17.8	16.0	14.0	11.7	223 / 101	
954246	White FG	White	Aluminum	Galv.	1.5 / 1725	Three	60 Hz	208-230/460	4.86A @ 230V @ .30 SP	15673	32,200	30,600	28,900	27,100	24,800	21,800	17,200	253 / 115	
954246-SC	White FG	White	Aluminum	SS	1.5 / 1725	Three	60 Hz	208-230/460	4.86A @ 230V @ .30 SP	15673	23.8	21.5	19.6	17.8	15.9	13.6	10.6	253 / 115	
954241	White FG	White	Galvanized	Galvanized	1.5 / 1725	Three	60 Hz	208-230/460	4.85A @ 230V @ .30 SP	15672	31,400	30,100	28,600	27,000	24,900	22,500	19,000	248 / 112	
954241	White FG	White	Galvanized	Galvanized	1.5 / 1725	Three	60 Hz	208-230/460	4.85A @ 230V @ .30 SP	15672	23.1	21.3	19.5	17.9	16.1	14.1	11.7	248 / 112	
954281	White FG	White	Aluminum	Galv.	1.5 / 1725	Three	60 Hz	208-230/460	6.56A @ 230V @ .30 SP	-	35,900	34,600	32,800	31,100	29,400	27,500	24,900	263 / 119	
954281-SC	White FG	White	Aluminum	SS	1.5 / 1725	Three	60 Hz	208-230/460	6.56A @ 230V @ .30 SP	-	18.4	17.2	15.8	14.6	13.4	12.3	10.9	263 / 119	
954286	White FG	White	Galvanized	Galvanized	1.5 / 1725	Three	60 Hz	208-230/460	6.60A @ 230V @ .30 SP	-	33,500	32,200	30,900	29,100	27,700	25,700	23,400	257 / 117	
954286	White FG	White	Galvanized	Galvanized	1.5 / 1725	Three	60 Hz	208-230/460	6.60A @ 230V @ .30 SP	-	18.4	17.2	15.8	14.6	13.4	12.3	10.9	257 / 117	
954256	White FG	White	Aluminum	Galv.	1.5 / 1425	Three	50 Hz	190 / 380	2.46A @ 380V @ .30 SP	17076	31,200	29,600	27,600	25,400	22,700	19,600	10,500	253 / 115	
954256-SC	White FG	White	Aluminum	SS	1.5 / 1425	Three	50 Hz	190 / 380	2.46A @ 380V @ .30 SP	17076	26.6	23.9	21.4	19.1	16.5	13.9	7.5	253 / 115	
954296	White FG	White	Galvanized	Galvanized	1.5 / 1425	Three	50 Hz	190 / 380	2.98A @ 380V @ .30 SP	17078	32,200	30,900	29,400	27,800	25,700	23,200	20,400	247 / 112	
954296	White FG	White	Galvanized	Galvanized	1.5 / 1425	Three	50 Hz	190 / 380	2.98A @ 380V @ .30 SP	17078	21.5	19.8	18.3	16.8	15.2	13.5	11.6	247 / 112	

SHORT CONE, EXTERIOR MOUNT

954811	White FG	White	Aluminum	Galv.	1.5 / 1725	Single	60 Hz	230	6.3A @ 230V @ .25 SP	22161	29,300	27,700	25,900	24,000	21,700	18,700	12,400	409 / 186	
954811-SSH	White FG	White	Aluminum	SS	1.5 / 1725	Single	60 Hz	230	6.3A @ 230V @ .25 SP	22161	23.2	21.2	19.1	17.4	15.4	13.0	8.9	262 / 119	
954816	White FG	White	Galvanized	Galvanized	1.5 / 1725	Single	60 Hz	230	6.04A @ 230V @ .30 SP	22162	27,800	26,900	25,200	23,400	21,200	18,500	14,200	395 / 179	
954816	White FG	White	Galvanized	Galvanized	1.5 / 1725	Single	60 Hz	230	6.04A @ 230V @ .30 SP	22162	23.2	21.6	19.7	17.8	15.8	13.5	10.4	395 / 179	

HYPERMAX / V-FAN 54" SHUTTERS

CATALOG NUMBER	ITEM DESCRIPTION	OUTSIDE DIMENSIONS HEIGHT x WIDTH	SHUTTER DIMENSIONS HEIGHT x WIDTH	SHIP WGHT.		LIST PRICE
				LBS	KGS	
SPM54W	54" Shutter - White PVC	61.5" x 61.5"	59" x 59"	34.0	15.4	
SPM54B	54" Shutter - Black PVC	61.5" x 61.5"	59" x 59"	30.0	13.6	
SPM54A	54" Shutter - Aluminum	61.35" x 61.35"	58.25" x 58.25"	38.0	17.2	

FIBERGLASS FAN SERIES

MACH 57™ 57" BELT DRIVE DAMPER FANS

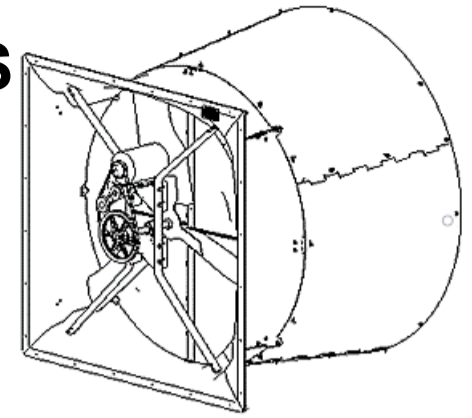
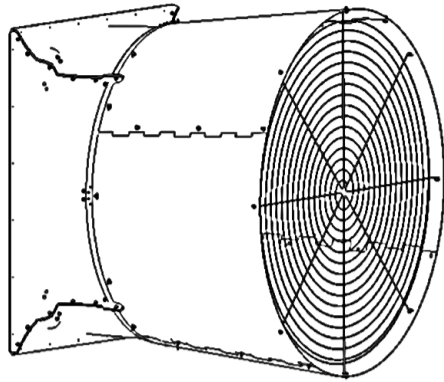

Fan comes complete with Damper and Cone
 VAL-CO® warranty does not apply for equipment against snow or ice damage.

MACH 57™ LONG CONE, EXTERIOR MOUNT

CATALOG NUMBER	Housing	Cone Color	Blade	Motor Mount	Motor / Electric							SHIP Weight	LIST PRICE EACH						
					HP / RPM	Phase	Hertz	Volts	Amps	BESS #	@ .00" SP			@ .05" SP	@ .10" SP	@ .15" SP	@ .20" SP	@ .25" SP	@ .30" SP
											CFM			CFM	CFM	CFM	CFM	CFM	CFM

Single Phase / 60Hz

957555	Black FG	Black	Galvanized	Galvanized	1.5 / 1725	Single	60 Hz	230V	6.59A @ 380V @ .3" SP	24077	33,300	31,200	29,400	26,800	24,000	20,800	16,900	226 / 103	
957555-KD-Q12	Black FG	Black	Galvanized	Galvanized	1.5 / 1725	Single	60 Hz	230V	6.59A @ 380V @ .3" SP	24077	29.2	25.3	22.5	19.5	16.7	14.1	11.3	2911 / 1320	
957570	Black FG	White	Galvanized	Galvanized	2.0 / 1725	Single	60 Hz	208-230V	8.97A @ 23V @ .3" SP	24069	36,200	34,400	32,600	30,500	28,400	25,600	22,900	227 / 103	
957570-KD-Q12	Black FG	White	Galvanized	Galvanized	2.0 / 1725	Single	60 Hz	208-230V	8.97A @ 23V @ .3" SP	24069	24.2	21.5	19.3	17.2	15.3	13.5	11.7	2592 / 1176	

Three Phase / 60Hz

957525	Black FG	White	Galvanized	Galvanized	1.5 / 1725	Three	60 Hz	208-230 / 460V	4.62A @ 230V @ .3" SP	24081	33,300	31,200	29,100	27,000	23,900	20,700	17,400	216 / 98	
957525-KD-Q12	Black FG	White	Galvanized	Galvanized	1.5 / 1725	Three	60 Hz	208-230 / 460V	4.62A @ 230V @ .3" SP	24081	29.2	25.3	22.1	19.5	16.7	14.1	11.6	2592 / 1176	
957580	Black FG	White	Galvanized	Galvanized	2.0 / 1725	Three	60 Hz	208-230 / 460V	5.42A @ 380V @ .3" SP	24080	35,900	34,100	32,000	30,000	27,500	24,900	22,100	250 / 113	
957580-KD-Q12	Black FG	White	Galvanized	Galvanized	2.0 / 1725	Three	60 Hz	208-230 / 460V	5.42A @ 380V @ .3" SP	24080	25.9	22.9	20.2	18.0	15.9	14.0	12.1	2600 / 1179	

Single Phase / 50Hz

957590	Black FG	White	Galvanized	Galvanized	2.0 / 1425	Single	50 Hz	208-230V	9.16A @ 220V @ .3" SP	24072	34,000	32,000	30,100	27,600	24,900	21,500	18,400	250 / 113	
957590-KD-Q12	Black FG	White	Galvanized	Galvanized	2.0 / 1425	Single	50 Hz	208-230V	9.16A @ 220V @ .3" SP	24072	25.7	22.7	20.2	17.6	15.4	12.9	10.9	2600 / 1179	

Three Phase / 50Hz

957530	Black FG	White	Galvanized	Galvanized	1.5 / 1425	Three	50 Hz	190 / 380V	5.56A @ 190V @ .3" SP	24082	33,700	31,700	29,700	27,300	24,300	21,100	17,600	216 / 98	
957530-KD-Q12	Black FG	White	Galvanized	Galvanized	1.5 / 1425	Three	50 Hz	190 / 380V	5.56A @ 190V @ .3" SP	24082	27.5	24.0	21.1	18.5	15.9	13.5	11.0	2592 / 1176	

* KD-Q12 - Knocked down quantity 12 is an unassembled version of 12 fans worth of parts packed to save space for shipping

Fan Assembly Jig

950160	Knock Down Fixture for Fan Assembly																6.0 / 2.7	
--------	-------------------------------------	--	--	--	--	--	--	--	--	--	--	--	--	--	--	--	-----------	--

BOX FANS

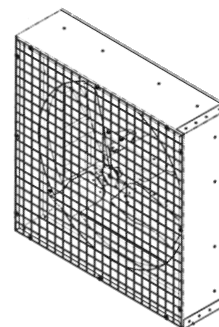

36" BOX FANS - DIRECT DRIVE

CATALOG NUMBER	ORIFICE SIZE	HOUSING MATERIAL	Phase	MOTOR/ELECTRIC			MATERIALS		CFM	CFM/Watt	BESS #	SHIP WEIGHT		LIST PRICE EACH
				HP	HZ	VOLTS	BLADE	MOTOR MOUNT				LBS.	KGS	
							RPM							
936425-ZM	36"	Z*	1	1/2	50	110/220	Galvanized	8900	19.1	C21241	90.0	40.8		
				850	60	115/208-230	Z	10470	18.7	C21240				
936435-ZM	36"	Z*	3	1/2	50	190/380	Galvanized	8830	26.3	C21230	97.7	44.3		
				850	60	230/460	Z	10190	21.0	C21229				

54" BOX FANS - BELT DRIVE

CATALOG NUMBER	ORIFICE SIZE	HOUSING MATERIAL	Phase	MOTOR/ELECTRIC			MATERIALS		CFM	CFM/Watt	SHIP WEIGHT		LIST PRICE EACH
				HP	HZ	VOLTS	BLADE	MOTOR MOUNT			LBS.	KGS	
							RPM						
954425-ZM	54"	Z*	1	1-1/2	60	230	Galvanized	28500**	237.0	107.5			
				1725			Z	21.9**					
954435-ZM	54"	Z*	3	1-1/2	60	208-230/460	Galvanized	28500**	198.0	89.8			
				1725			Z	21.9**					

* Z Protective coating used for the fan orifice, housing, and cone. 7 year rust through warranty on housings (Poultry Application).

**Estimated

HORIZONTAL AIRFLOW FANS

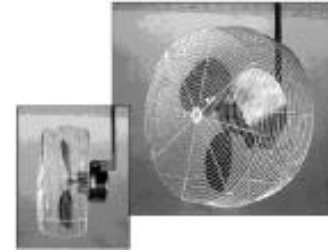

HAF SERIES AG CIRCULATING FANS

CATALOG NUMBER	ITEM DESCRIPTION	Bess #	MOTOR / Amps HP / RPM	CFM		VOLTS		SHIPPING WEIGHT		LIST PRICE
				CFM / Watt	PHASE-HERTZ	LBS.	KGS			
HF20N01	20" Horizontal Airflow Fan, OSHA Compliant, Powder Coated White Guard	C18050	2.1 / 1.1 .33 / 1725	3040 8.2	115/230 1Ph-60Hz	30.0	13.6			
HF24N01	24" Horizontal Airflow Fan, OSHA Compliant, Powder Coated White Guard	C23231	3.6 / 1.9 .50 / 1725	7760 17.2	115/230 1Ph-60Hz	37.0	16.8			
936420	36" Horizontal Airflow Fan, OSHA compliant Powder Coated White Guard KD is an Unassembled Version	C23230	6.9 / 3.45	9280	115/208-230	42.0	19.1	-----	-----	
936420-KD			.5 / 825	16.6	1Ph-60Hz					
936420		C23229	8.3 / 4.1	7840	110/220	42.0	19.1	-----	-----	
936420-KD	.5 / 700		16.8	1Ph-50Hz						
936430	36" Horizontal Airflow Fan, Powder Coated White Guard KD is an Unassembled Version	C23227	2.3/1.2	8990	230/460	43.0	19.5	-----	-----	
936430-KD			.5 / 824	19.3	3Ph-60Hz					
936430		C23228	2.0/1.0	7570	190/380	43.0	19.5	-----	-----	
936430-KD	.5 / 700		24	3Ph-50Hz						

Catalog Number	Blade Dia. (in)	Basket Dia. (in)	Basket Ht (in)	Motor Ht (in)	Motor Protrusion (in)	Overall Height (in)
HF20N01	20	23.122		6.5	4.25	14.75
HF24N01	24	27.122	10.75	6.625	4.75	15.50
936420	36	39.122	10.25	8.00	6.00	16.25
936430	36	39.122	10.25	7.875	5.875	16.125

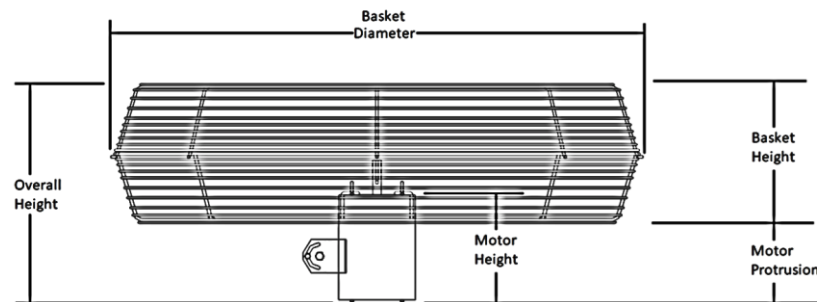

HAF SERIES AG CIRCULATING FANS - BRACKETS

CATALOG NUMBER	ITEM DESCRIPTION	SHIPPING WEIGHT		LIST PRICE
		LBS.	KGS	
980174	Truss Bracket for 12" thru 24" HAF Fans- Galvanized	2.7	1.2	
980172	Truss Bracket for 24" & 36" HAF Fans - Galvanized	3.5	1.6	
HFWB1224	Wall/Post Bracket for 12" thru 24" HAF Fans - Black Powder Coat	8.5	3.8	
972430	Wall/Post Bracket for 36" HAF Fans - Galvanized	9.4	4.3	
980175	Ceiling Bracket for 12"-24" HAF Fans - Galvanized	2.1	1.0	
HFCEB36	Ceiling Bracket for 36" HAF Fans - Black Powder Coat	3.4	1.5	

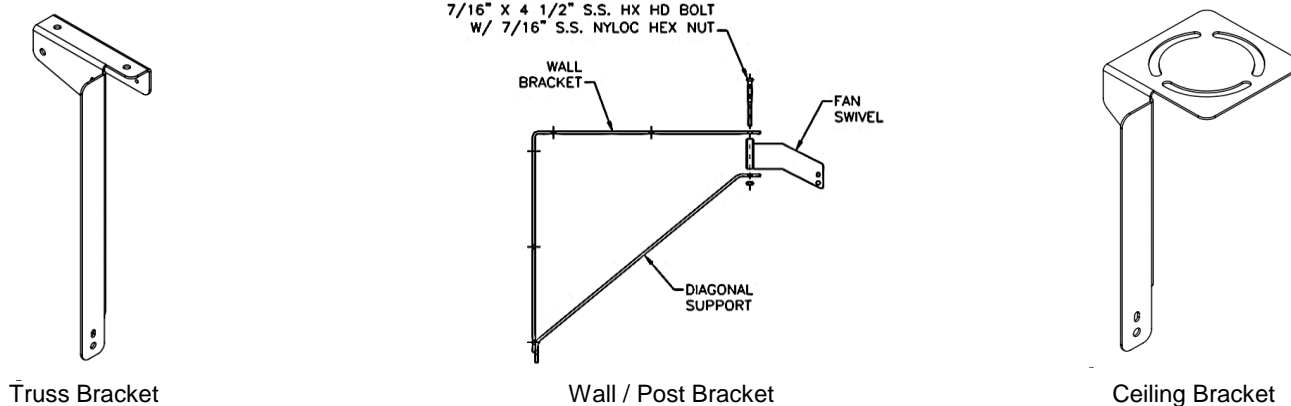

FAN ACCESSORIES

PIT FAN ADAPTERS & ELBOWS

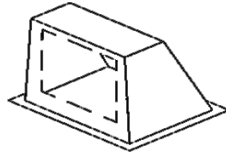

Pump Out Adapter

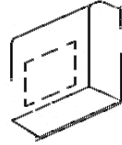

Vertical Fan Transition

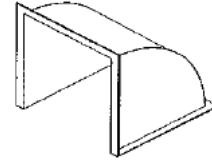

Pit Fan Elbow

PIT FAN ADAPTERS

CATALOG NUMBER	ITEM DESCRIPTION	SHIP WEIGHT		LIST PRICE
		LBS.	KGS.	
E407	Fiberglass Pit Fan Elbow for 21" PMC Fan	18.0	8.2	
E505	Small Vertical Transition With 16" PMC Slides	43.0	19.5	
E506	Large Vertical Transition With 21" PMC Slides	50.0	22.7	
E507	Large Vertical Transition With 24" PMC Slides	50.0	22.7	
E604	Small Pumpout Adapter With 12" PMC Slides	34.0	15.4	
E605	Small Pumpout Adapter With 16" PMC Slides	34.0	15.4	
E606	Large Pumpout Adapter With 21" PMC Slides	40.0	18.1	
E607	Large Pumpout Adapter With 24" PMC Slides	40.0	18.1	

All E5XX-series pit fan adapters come standard with stainless steel slides.

FAN ACCESSORIES

WINTER DOORS & WIND DIVERTERS

WINTER DOORS

CATALOG NUMBER	ITEM DESCRIPTION	Ax	Ay	Bx	By	SHIP WEIGHT		LIST PRICE
						LBS.	KGS.	
WD405-12	Winter Door for 12" PMC Fan	20.00	20.00	17.68	17.68	0.0	0.0	
WD406	Winter Door Kit for 16" PMC Fan	24.25	24.25	21.93	21.93	7.4	4.0	
WD407-20	Winter Door for 21" PMC Fan	28.00	28.00	25.68	25.68	0.0	0.0	
WD408	Winter Door Kit for 24" PMC Fan	30.06	30.06	27.75	27.75	7.4	4.0	
WD409	Winter Door Kit for 36" Fan	45.31	45.31	43.00	43.00	15.3	7.0	
WD410	Winter Door Kit for 48" Fan	57.00	57.00	54.68	54.68	23.4	11.0	
WD411	Winter Door Kit for 50" Fan	57.00	59.06	54.68	56.74	24.3	12.0	
WD415	Winter Door Kit for 54" Fan	61.50	61.50	59.18	59.18	26.6	13.0	

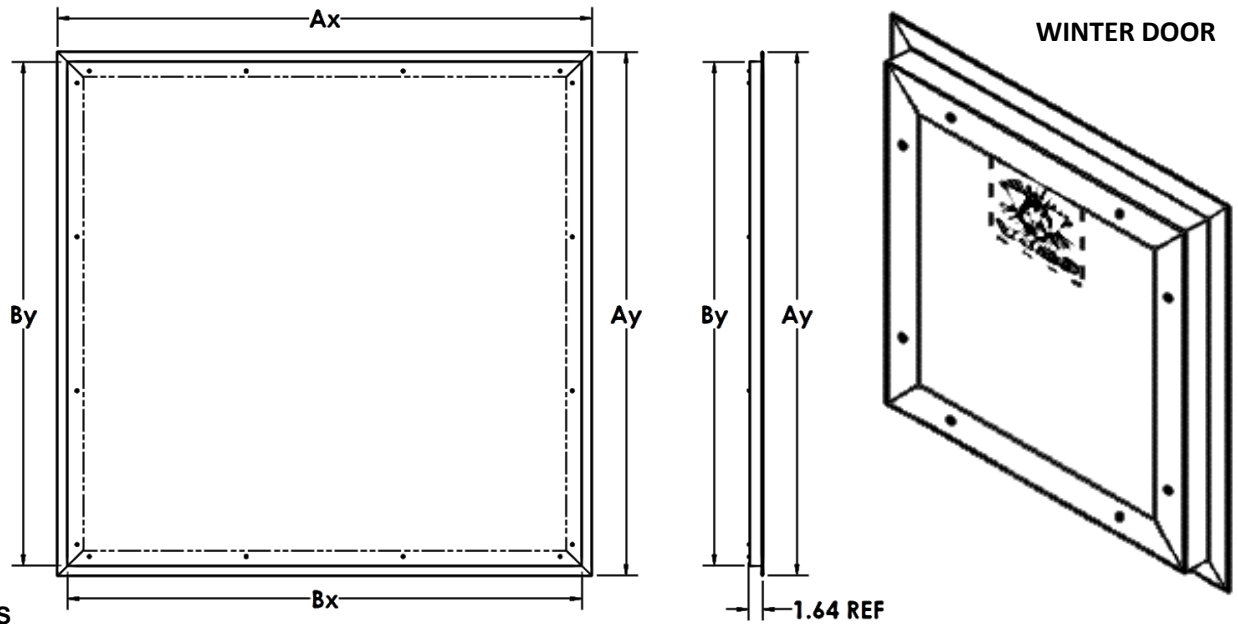

WIND DIVERTERS

CATALOG NUMBER	ITEM DESCRIPTION	SHIP WEIGHT		LIST PRICE
		LBS.	KGS.	
ZW1126	Wind Baffle for 12" PMC Fan	6.0	3.0	
ZW1125	Wind Baffle for 16" PMC Fan	8.0	4.0	
ZW1127	Wind Baffle for 21" PMC Fan	12.0	6.0	
ZW1129	Wind Baffle for 24" PMC Fan	12.0	6.0	

Wind Diverters include Baffle, Mounting Brackets and Hardware.



LIGHT TRAP KITS FOR IN FRONT OF EXHAUST FANS

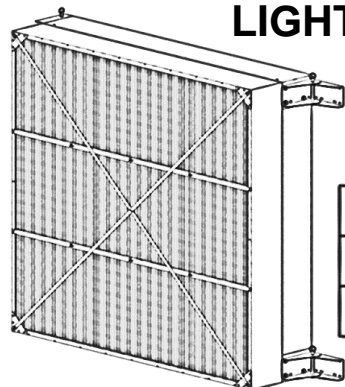

	A (Width Clearance)		B (Height Clearance)		C (Clearance in Closed Position)		D (Clearance in Open Position)	
	in	cm	in	cm	in	cm	in	cm
819000 72" X 72"	84	213.4	74.5	189.2	19	48.3	79	200.7
819010 60" X 60"	72	182.9	62.5	158.8	19	48.3	67	170.2
819020 48" X 48"	60	152.4	50.5	128.3	19	48.3	55	139.7

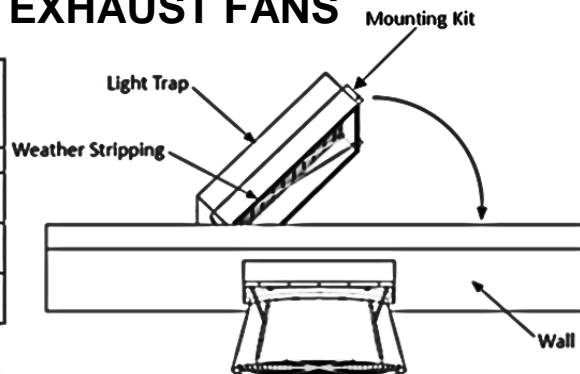

How to Order: - Order (1) Mounting Kit and (1) Framed Light Trap. Fan and shutters sold separately.

MOUNTING KITS - Ships Unassembled - ONLY USED WITH FRAMED LIGHT TRAPS

CATALOG NUMBER	ITEM DESCRIPTION	Typical used with Size Exhaust Fan	SHIP WEIGHT		LIST PRICE
			LBS.	KGS.	
819020	9" Deep Mounting Kit for 48" x 48" Framed Light Trap	12" - 24"	64.3	30.0	
NAK48A48F	Light Trap 48H x 48W x 3/4" Spacing Galvanized Frame Assembled		97.1	45.0	
NAK48B48F	Light Trap 48H x 48W x 1" Spacing Galvanized Frame Assembled		102.5	47.0	
NAK48A48FU	Light Trap 48H x 48W x 3/4" Spacing Galvanized Frame Unassembled		97.1	45.0	
NAK48B48FU	Light Trap 48H x 48W x 1" Spacing Galvanized Frame Unassembled		78.6	36.0	
819010	9" Deep Mounting Kit for 60" x 60" Framed Light Trap	36" - 48"	82.2	38.0	
NAK60A60F	Light Trap 60H x 60W x 3/4" Spacing Galvanized Frame Assembled		148.0	68.0	
NAK60B60F	Light Trap 60H x 60W x 1" Spacing Galvanized Frame Assembled		122.2	56.0	
NAK60A60FU	Light Trap 60H x 60W x 3/4" Spacing Galvanized Frame Unassembled		156.2	71.0	
NAK60B60FU	Light Trap 60H x 60W x 1" Spacing Galvanized Frame Unassembled		122.2	56.0	
819000	9" Deep Mounting Kit for 72" x 72" Framed Light Trap	50" - 54"	95.6	44.0	
NAK72A72F	Light Trap 72H x 72W x 3/4" Spacing Galvanized Frame Assembled		204.3	93.0	
NAK72B72F	Light Trap 72H x 72W x 1" Spacing Galvanized Frame Assembled		167.0	76.0	
NAK72A72FU	Light Trap 72H x 72W x 3/4" Spacing Galvanized Frame Unassembled		206.0	94.0	
NAK72B72FU	Light Trap 72H x 72W x 1" Spacing Galvanized Frame Unassembled		166.7	76.0	

Light Traps in front of Exhaust Fans will increase the static pressure, see page 31-02 for air flow data or contact VAL-CO App. Engineering Hinged design. Sits into Room 18" when door is closed

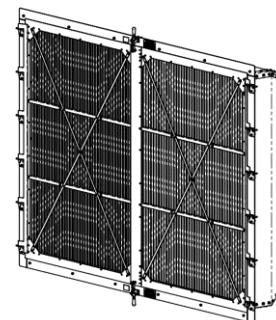

How to Order: - Order (1) Flush Mount Framed Light Trap. Fan & Shutters sold separately.

FLUSH MOUNT NightAir FAN TRANSITIONS (Black-out) - Ships Unassembled

CATALOG NUMBER	ITEM DESCRIPTION	Use With Exhaust Fan	SHIP WEIGHT		LIST PRICE
			LBS.	KGS.	
819025	Flush Mount Framed Light Trap 48H x 48W x 1" - unassembled	24" FG Fans	260.0	118.0	
819075	Flush Mount Framed Light Trap 60H x 72W x 1" - unassembled	36" FG Fans	335.0	152.0	
819045	Flush Mount Framed Light Trap 84H x 72W x 1" - unassembled	54" FG Fans	475.0	216.0	

FLUSH MOUNT ECLIPSE FAN TRANSITIONS (Brown-out) - Ships Unassembled

819225	Flush Mount Framed Light Trap H x W x 1" - unassembled	24" FG Fans	#N/A	#N/A	
819215	Flush Mount Framed Light Trap 60H x 72W x 1" - unassembled	36" FG Fans	335.0	152.0	
819245	Flush Mount Framed Light Trap 72H x 72W x 1" - unassembled	54" FG Fans	273.0	124.0	
819255	Flush Mount Framed Light Trap 84H x 72W x 1" - unassembled	54" FG Fans	355.0	162.0	

Light Traps in front of Exhaust Fans will increase the static pressure, see page 31-02 for air flow data or contact VAL-CO App. Engineering . Light Trap is included. Hinged design

ADAPTER KIT - MACH 57"

819240	Adapter kit to mount a Mach 57 Fan to either 819045 or 819255	57" FG Fans	25.5	12.0	
--------	---	-------------	------	------	--

Hemisphere® Centrifugal Circulation Fans



Hemisphere® Centrifugal Circulation Fans

CATALOG NUMBER	ITEM DESCRIPTION	SHIPPING WEIGHT		LIST PRICE
		LBS.	KGS	
972420	Hemisphere Fan, 48" W/ Wire Guard, 32,000 cfm*, 1½ HP, 60 Hz, 1 PH, 115/208-230V, not VFD Controllable	353.0	161.0	
972420-Q2	Quantity of 2 - 972420 per skid	608.0	276.0	
972420-Q3	Quantity of 3 - 972420 per skid	863.0	392.0	
972420-Q4	Quantity of 4 - 972420 per skid	1118.0	508.0	
972180	Hemisphere Fan, High Capacity, 48" W/ Wire Guard, 32,000 cfm*, 1½ HP, 60 Hz, 3 PH, 208-230/460 V, VFD Controllable	342.0	156.0	
972180-Q2	Quantity of 2 - 972180 per skid	586.0	266.0	
972180-Q3	Quantity of 3 - 972180 per skid	830.0	377.0	
972180-Q4	Quantity of 4 - 972180 per skid	1075.0	488.0	
972120	Hemisphere Fan, 72" W/ Wire Guard, 45,500 cfm*, 1½ HP, 60 Hz, 3 PH, 208-230/460 V, VFD Controllable	491.0	223.0	
972120-Q2	Quantity of 2 - 972120 per skid	861.0	391.0	
972120-Q3	Quantity of 3 - 972120 per skid	1232.0	559.0	
972120-Q4	Quantity of 4 - 972120 per skid	1602.0	727.0	
972280	Hemisphere Fan, 72" W/ Wire Guard, 45,000 cfm*, 1½ HP, 60 Hz, 1 PH, 115/208-230 V, Not VFD Controllable	525.0	239.0	
972280-Q2	Quantity of 2 - 972280 per skid	929.0	422.0	
972280-Q3	Quantity of 3 - 972280 per skid	1332.0	605.0	

* Estimated

** Motor Name Plate: 60Hz, 3HP, Volts 208-230/460, FL Amps 15-14.4/7.2, 3PH; 50Hz, 2HP, Volts 190/380, FL Amps 14/7

Hemisphere® Centrifugal Circulation Fan Options:

Chimney Inlet, Shaft Conversion and Variable Speed Drive Panels

CATALOG #	ITEM DESCRIPTION	LBS.	KGS	LIST PRICE
812245	24" Chimney Kit, Hemisphere Fan, F/ Attic	56.5	26.0	
812265	24" Chimney Kit, Hemisphere Fan, W/ Dome Flashing & Bird Netting	110.9	51.0	
812230	24" Roof Chimney Flashing (peak)	15.4	7.0	
812340	30" Attic Inlet for Hemisphere Fans RO:32.5" x 35"	50.6	23.0	
812365	36" Chimney Kit, Hemisphere Fan, F/ Attic ***	68.9	32.0	
812385	36" Chimney Kit, Hemisphere Fan, W/ Dome & Bird Netting ***	145.4	66.0	
812330	36" Roof Chimney Flashing (peak)	21.4	10.0	
972139	Hex Shaft Conversion Parts for Welded Frame Hemisphere fans	7.0	4.0	
972194	Hex Shaft Conversion Parts for Round Shaft Hemisphere fans	15.5	8.0	
921893	VFD; 200-240 V, 1PH input, 7.0 Amp Out Max.	6.5	3.0	
922139	VFD; 200-240 V, 3PH input, 7.0 Amp Out Max.	6.5	3.0	
921885	Manual Fan Speed Reference Control Station	0.0	1.0	
921762	10A Motor Starter, IP55	1.8	1.0	

*** 36" chimneys to be used with 72" hemispheres

Hemisphere® Directional Centrifugal Circulation Fans & Z-Pro™ Hemisphere® Fans & Acc.

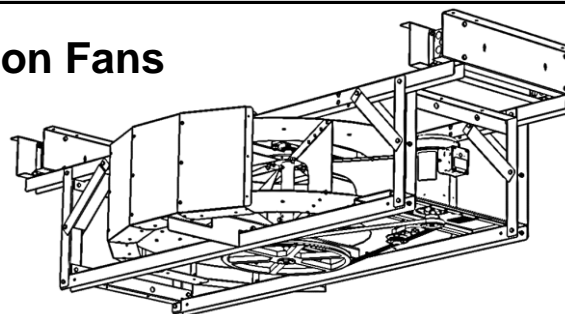

Directional Hemisphere® Centrifugal Circulation Fans

CATALOG NUMBER	ITEM DESCRIPTION	SHIPPING WEIGHT		LIST PRICE
		LBS.	KGS	
972185	Directional Hemisphere Fan, High Capacity, 48" W/ Wire Guard, 21,000 cfm*, 1½ HP, 60 Hz, 3 PH, 208-230/460 V, VFD Controllable	406.0	185.0	
972185-Q2	Quantity of 2 - 972185 per skid	688.0	313.0	
972185-Q3	Quantity of 3 - 972185 per skid	984.0	447.0	
972185-Q4	Quantity of 4 - 972185 per skid	1279.0	581.0	
972425	Directional Hemisphere Fan, High Capacity, 48" W/ Wire Guard, 21,000 cfm*, 1½ HP, 60 Hz, 1 PH, 115/208-230 V, Not VFD Controllable	401.0	182.0	
972425-Q2	Quantity of 2 - 972425 per skid	707.0	321.0	
972425-Q3	Quantity of 3 - 972425 per skid	1013.0	460.0	
972425-Q4	Quantity of 4 - 972425 per skid	1317.0	598.0	
972125	Directional Hemisphere Fan, Standard Capacity, 72" W/ Wire Guard, 30,000 cfm*, 1½ HP, 60 Hz, 3 PH, *230/460 V, VFD Controllable	649.0	295.0	
972125-Q2	Quantity of 2 - 972125 per skid	1177.0	534.0	
972125-Q3	Quantity of 3 - 972125 per skid	1705.0	774.0	
972125-Q4	Quantity of 4 - 972125 per skid	2233.0	1013.0	

* Estimated

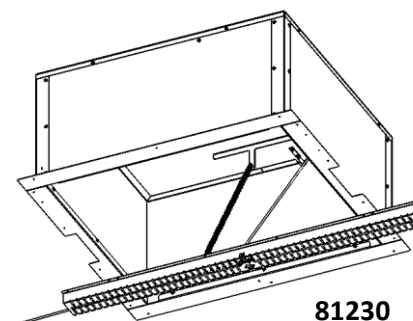
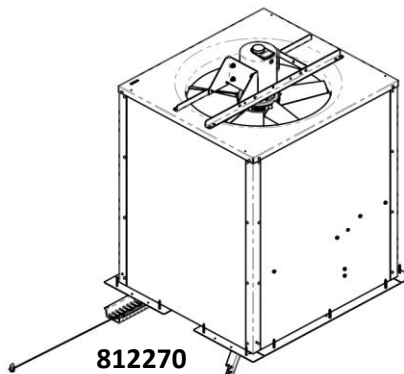
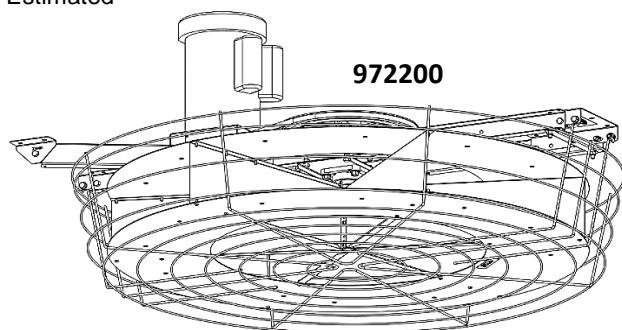

Z-Pro™ Hemisphere® Mixing Fans

972200	Hemisphere Fan, High Capacity, 42" W/ Wire Guard, Zinc-Plated Hardware 25,000 cfm*, 1½ HP, 60 Hz, 1 PH, 115/208-230V, Not VFD Controllable	108.6	50.0	
972200-SC	Hemisphere Fan, High Capacity, 42" W/ Wire Guard, Stainless Steel Hardware 25,000 cfm*, 1½ HP, 60 Hz, 1 PH, 115/208-230V, Not VFD Controllable	108.6	50.0	
972220	Hemisphere Fan, High Capacity, 42" W/ Wire Guard, Zinc-Plated Hardware 25,000 cfm*, 1½ HP, 60 Hz, 3 PH, 208-230/460V, VFD Controllable	114.0	52.0	
972220-SC	Hemisphere Fan, High Capacity, 42" W/ Wire Guard, Stainless Steel Hardware 25,000 cfm*, 1½ HP, 60 Hz, 3 PH, 208-230/460V, VFD Controllable	114.0	52.0	
972205	Kit includes 972200 Hemisphere Mixing Fan and 812305 Attic Inlet Kit	221.8	101.0	
972205-SC	Kit includes 972200-SC Hemisphere Mixing Fan and 812305 Attic Inlet Kit	221.8	101.0	
972225	Kit includes 972220 Hemisphere Mixing Fan and 812305 Attic Inlet Kit	227.1	103.0	
972225-SC	Kit includes 972220-SC Hemisphere Mixing Fan and 812305 Attic Inlet Kit	227.1	103.0	

Z-Pro™ Attic Kit and Accessories

812270	30" Attic Inlet Kit for Z-Pro Fans with 24" Panel Fan	113.9	52.0	
812305	30" Attic Inlet Kit for Z-Pro Fans RO:32.5" x 35"	46.2	21.0	
921893	VFD; 200-240 V, 1PH input, 7.0 Amp Out Max.	6.5	3.0	
922139	VFD; 200-240 V, 3PH input, 7.0 Amp Out Max.	6.5	3.0	
921885	Manual Fan Speed Reference Control Station	0.0	1.0	
921762	Motor Starter, 10 Amp, IP55	1.8	1.0	