

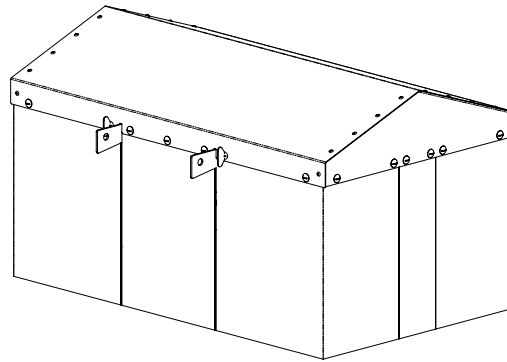

Flag Joint Weather Hood

501595

Quicksheet



Flag Joint Weather Hood - Assembly Instructions

1. Attach (2) Curtains (501598) to the pre-assembled Roof (501596/501597), using (22) 5/16-18 x 3/4" truss bolts (501440), (22) 5/16-18 hex nuts (010603), and (22) 5/16" flat washers (690407), as supplied in the provided hardware bag (501594). Refer to Figure 1 for assembly orientation. Tighten all hardware.

Figure 1

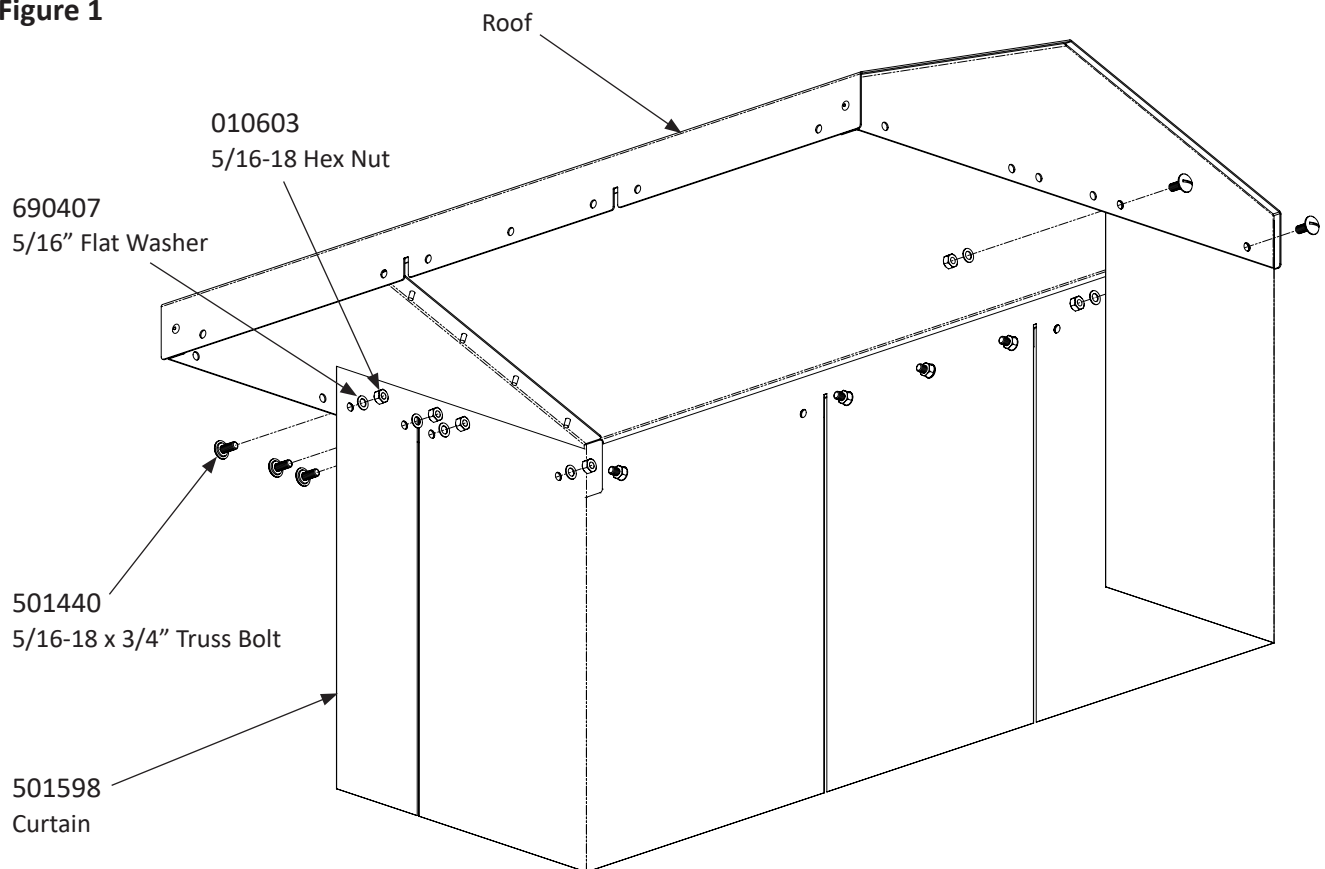

NOTE: Only one curtain is shown in this assembly view, for visual clarity.

Flag Joint Weather Hood - Assembly Instructions (continued)

2. Connect the Cross Bars to the existing Discharge Head Body and Motor to provide support for the previously assembled Roof and Curtain sub-assembly, using hardware supplied in the provided hardware bag (501594).

Attach (1) Cross Bar (501599) to the Discharge Head Body using (1) 3/8-16 x 1-1/4" hex bolt (010666), (1) 3/8-16 Nylock nut (012481), (1) 3/8" flat washer (690093), and (1) Port Tube Spacer Plate (501584), as shown in Figure 2.

NOTE: 740 Systems do **not** use the Port Tube Spacer Plate (501584), and in its place use (2) additional 3/8" flat washers (690093) as spacers.

Figure 2

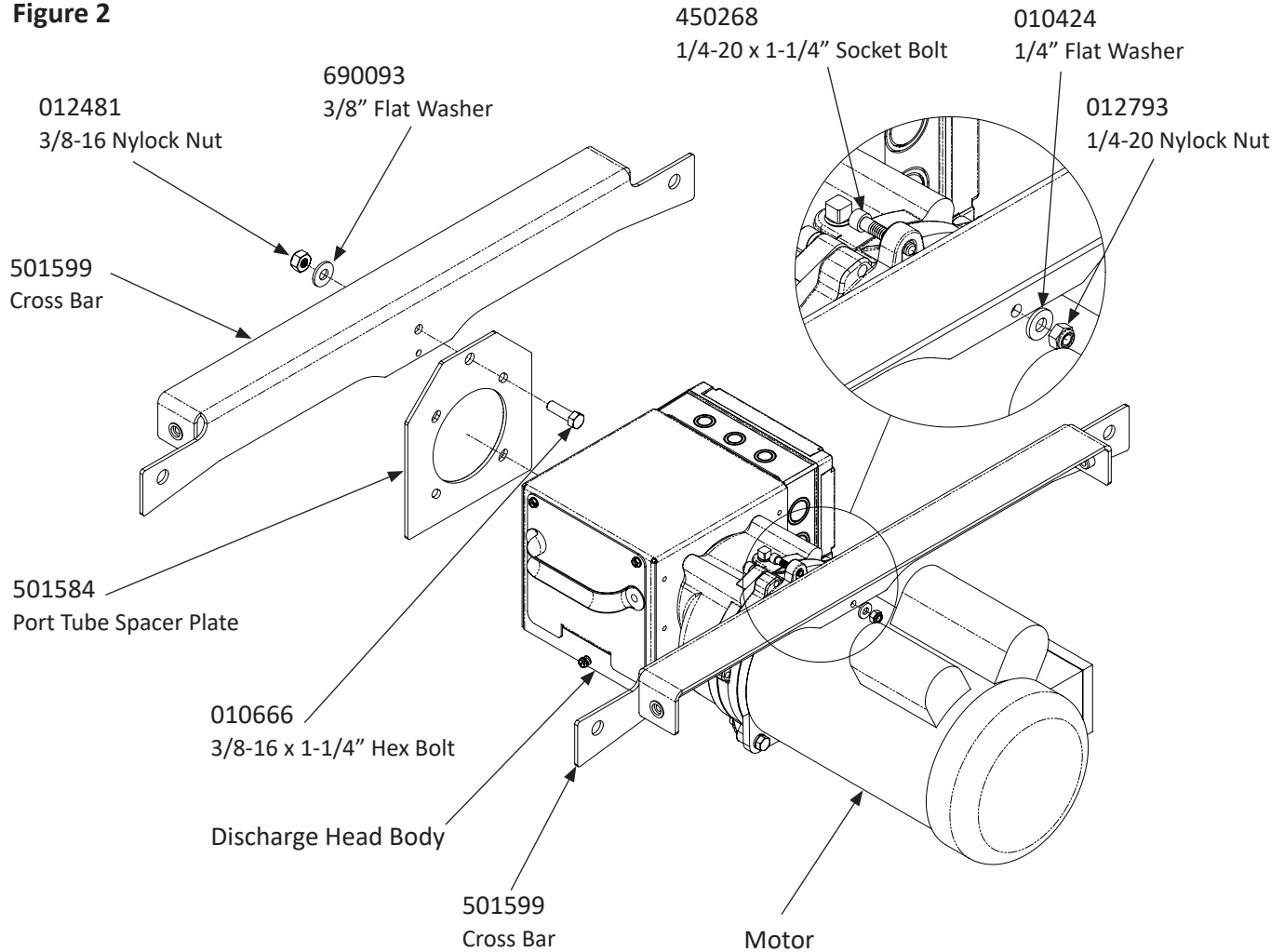

3. Attach (1) Cross Bar (501599) to the Motor using (1) 1/4-20 x 1-1/4" socket bolt (450268), (1) 1/4-20 Nylock nut (012793), and (1) 1/4" flat washer (010424), as shown in the detail view of Figure 2.

Flag Joint Weather Hood - Assembly Instructions (continued)

- Attach previously assembled Roof and Curtain sub-assembly to the (2) Cross Bars that are attached to the Discharge Head Body and Motor. Drop the Roof and Curtain sub-assembly down over the Cross Bars, aligning the slots in the Roof with the end tabs in the Cross Bars. Secure the Roof to the Cross Bars with (4) 5/16" x 3/4" thumbscrews (102019), supplied in the provided hardware bag (501594) to complete assembly, as shown in Figure 3.

Figure 3

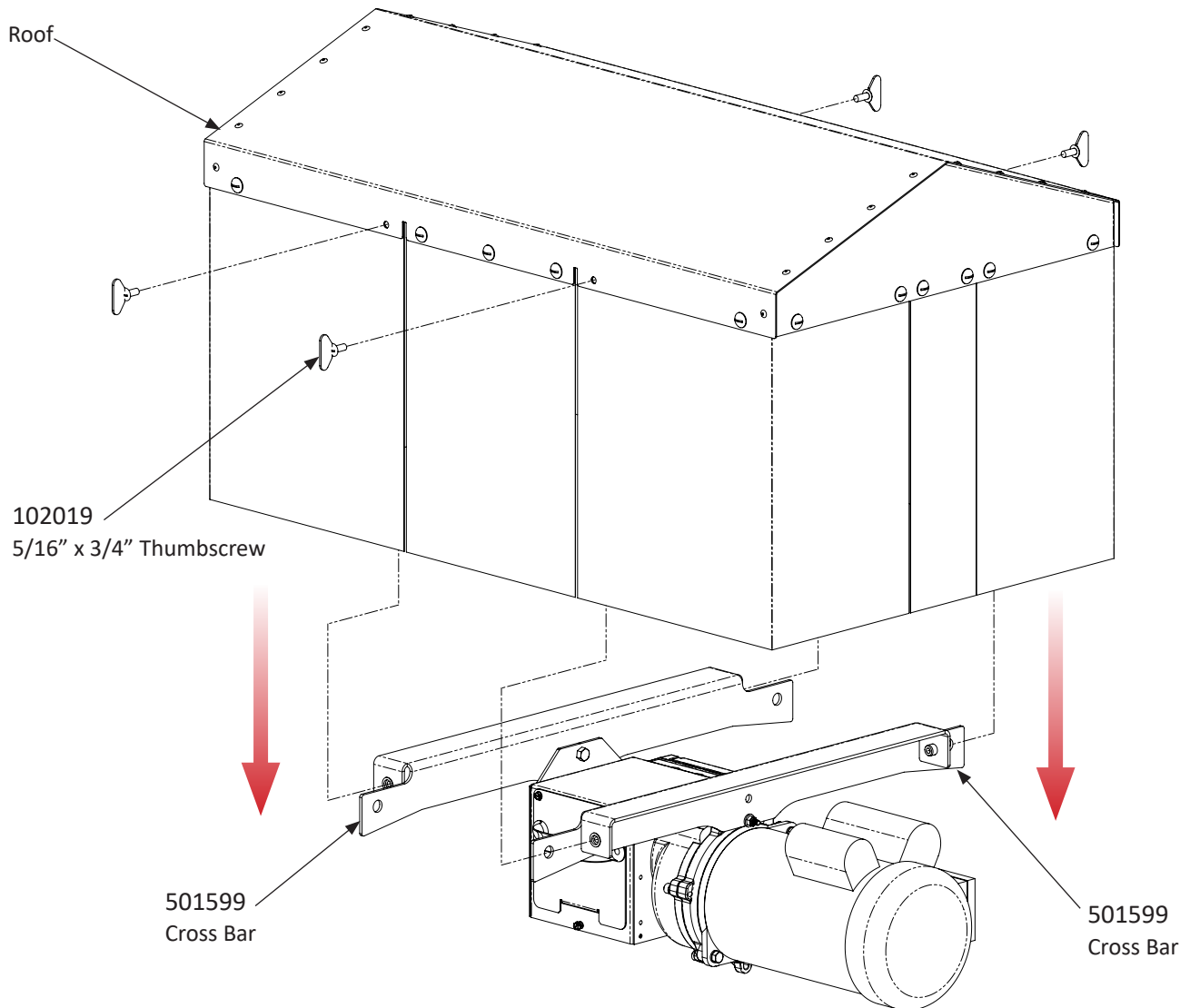

Flag Joint Weather Hood - Exploded Drawing and Parts List

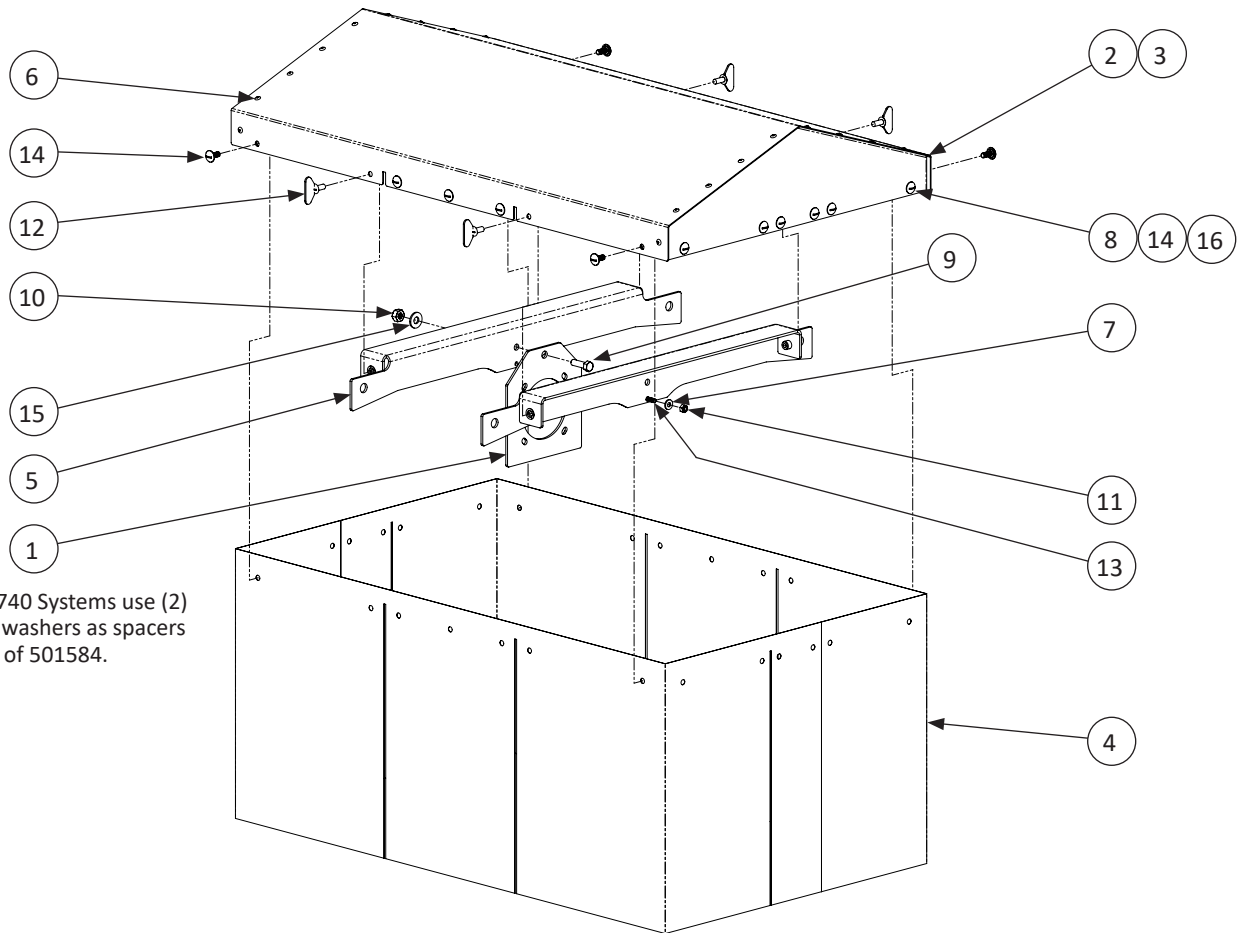

NOTE: 740 Systems use (2) 690093 washers as spacers in place of 501584.

KEY	PART #	DESCRIPTION	QTY
FLAG JOINT WEATHER HOOD (501595)			
1	501584	PLATE, PORT TUBE SPACER (<i>see note</i>)	1
-	501594	HARDWARE BAG FOR FLAG JOINT WEATHER HOOD	1
2	501596	ROOF	1
3	501597	END PANEL	2
4	501598	CURTAIN	2
5	501599	CROSS BAR	2
6	954099	3/16" X .126 X .250" POP RIVET	20
HARDWARE BAG FOR FLAG JOINT WEATHER HOOD (501594)			
7	010424	1/4" FLAT WASHER	1
8	010603	5/16-18 HEX NUT	22
9	010666	3/8-16 X 1-1/4" HEX BOLT	1
10	012481	3/8-16 NYLOCK HEX NUT	1
11	012793	1/4-20 NYLOCK HEX NUT	1
12	102019	5/16" X 3/4" THUMBSCREW	4
13	450268	1/4-20 X 1-1/4" SOCKET BOLT	1
14	501440	5/16-18 X 3/4" TRUSS BOLT	22
15	690093	3/8" FLAT WASHER	3
16	690407	5/16" FLAT WASHER	22

North America:

Phone: 800.99VALCO; 800.998.2526

Fax: 419.678.2200

Email: sales@val-co.com

990393

REV [-]

International:

Phone: (+1) 419.678.8731

Fax: (+1) 419.678.2200

Email: intl.sales@val-co.com